



IM CL HYDRO

Total volume
Capacità totale 24 lt.

Net weight
Peso netto 26 kg.

Power supply and
nominal consumption 12 Vdc 180 W
Alimentazione e
consumo nominale

Ice production (up to)
Produzione ghiaccio (fino a) 4,0 kg./24h

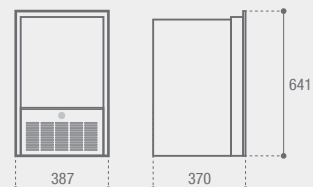

IM CL REFILL

Total volume
Capacità totale 24 lt.

Net weight
Peso netto 26 kg.

Power supply and
nominal consumption 12 Vdc 180 W
Alimentazione e
consumo nominale

Ice production (up to)
Produzione ghiaccio (fino a) 4,0 kg./24h

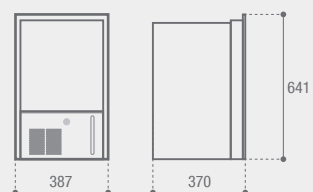

CHROMELOCK SERIES



FRIDGES AND FREEZERS



WITH BUILT-IN/REMOTE COOLING UNIT

FRIGORIFERI E FREEZER

CON UNITÀ INTERNA/ESTERNA

Available models *
Modelli disponibili *

Total volume
Capacità totale

	LT.			
DP2600i CHR	230	●		
DP150i CHR	150	●		
C115i - C115iA CHR	115	●	●	
C90i CHR	90	●		
C90DW CHR	90	●		●
C85i - C85iA CHR	85	●	●	
C62i CHR	62	●		
C60i - C60iA CHR	60	●	●	
C51i CHR	51	●		
C51DW CHR	51	●		●
C50i CHR	50	●	●	
C39i CHR	39	●	●	

C130L - C130LA CHR	130	●	●	
C95L - C95LA CHR	95	●	●	
C75L - C75LA CHR	75	●	●	
C75DW CHR	75	●	●	●
C42L CHR	42	●	●	
C42DW CHR	42		●	●
C25L CHR	25		●	

 Fridge/Freezer
Frigo/Congelatore

 Fridge
Frigo

 Drawer
Cassetto

NEW

* Chromelock series availability is continuously updated: please contact us at sales@vitrifrigo.com

* La disponibilità della serie Chromelock è in continua evoluzione: contattateci per gli ultimi aggiornamenti a sales@vitrifrigo.com



The new complete range

LA NUOVA GAMMA COMPLETA

The Airlock series evolves in Chromelock series: the new complete range that covers every requirement in terms of space and capacity. Ergonomic, quiet, intuitive and safe, it is able to guarantee maximum on-board comfort.

Models whose code end in "A" are equipped with a holding plate styled evaporator, which provides higher efficiencies and longer 'Off' time.

La serie Airlock evolve in Chromelock: la nuova gamma completa che copre tutte le esigenze in termini di spazio e di capacità. Ergonomica, silenziosa, intuitiva e sicura, è in grado di garantire il massimo del comfort a bordo.

I modelli il cui codice termina con la lettera "A" sono equipaggiati con un evaporatore ad accumulo di freddo, consentendone l'utilizzo anche a motore spento.

FRIDGES AND FREEZERS WITH BUILT-IN/REMOTE COOLING UNIT

FRIGORIFERI E FREEZER CON UNITÀ INTERNA/ESTERNA

CHROMELOCK



INNOVATION BELONGS TO THOSE WITH A HISTORY.

Chromelock is the evolution of a high-profile design and production experience, able to combine technological innovation and design, with the functionality and quality of Made in Italy, in the search for a unique style that successfully combines essential elegance, quality value and unique personality.

L'INNOVAZIONE APPARTIENE A CHI HA UNA STORIA.

Chromelock è l'evoluzione di un'esperienza progettuale e produttiva di alto profilo, in grado di abbinare l'innovazione tecnologica e il design, con la funzionalità e la qualità del Made in Italy, nella ricerca di uno stile unico che sa unire eleganza essenziale, valore della qualità, personalità distintiva.



INCREASED DOOR THICKNESS
ANTA A SPESSORE MAGGIORATO



**ANTI-FINGERPRINT AND SCRATCH RESISTANT
FINISH WITH SOFT TOUCH EFFECT**
FINITURA ANTI IMPRONTA ED ANTIGRAFFIO
CON EFFETTO SOFT TOUCH



REPLACEABLE SEAL
GUARNIZIONE SOSTITUIBILE



METAL FINISH HANDLE
MANIGLIA CON FINITURA
METALLIZZATA



VENT POSITION SYSTEM
SISTEMA VENT POSITION



Form ever follows function

LA FORMA SEGUE SEMPRE LA FUNZIONE

THE NEW DOOR

- lighter with the same overall dimensions and totally built-in, with a smooth and elegant side frame, 42 mm thick.
- reversible and available in two colour variants: Light Grey and Black. The Light Grey version has an elegant glossy grey laminated panel with a pearly effect, while in the Black version the panel is matt black with anti-fingerprint and scratch resistant finish with soft touch effect.
- possibility to use finishing panels from 0.8 to 3.0 mm thick, guaranteeing simple and ultra-fast installation
- removable seal for its replacement and cleaning

THE NEW CHROMELOCK HANDLE

- elegant metal finish tested for over 150,000 opening and closing cycles
- carries out a positive and safe closing of the door
- integrated "vent position"

LA NUOVA PORTA

- più leggera a parità di ingombro e incasso totale, con un profilo laterale liscio ed elegante da 42 mm. di spessore
- reversibile e disponibile in due varianti cromatiche: grigia (Light Grey) e nera (Black). La versione Light Grey ha un elegante pannello laminato grigio lucido ad effetto perlato, mentre nella versione Black il pannello è nero opaco con finitura anti impronta ed antigraffio con effetto soft touch.
- possibilità di utilizzare pannelli di finitura con spessori da 0,8 a 3,0 mm., per un'installazione semplice e ultrarapida
- guarnizione estraibile per la sua sostituzione e pulizia

LA NUOVA MANIGLIA CHROMELOCK

- elegante finitura metallizzata testata per oltre 150.000 cicli di apertura e chiusura
- effettua una chiusura positiva e sicura della porta
- "vent position" incorporata

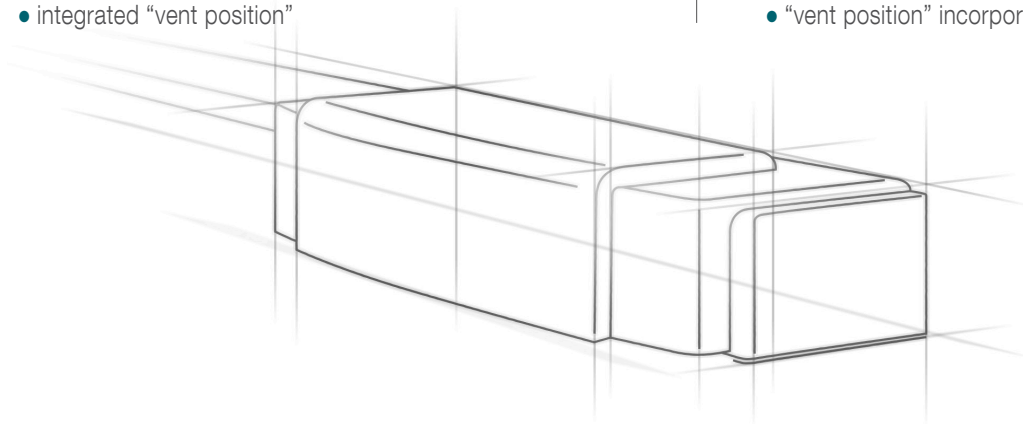



Chromelock: the smart locking system

CHROMELOCK: IL SISTEMA DI CHIUSURA INTELLIGENTE

The Chromelock system allows secure locking of the door even during intensive and extreme use of your boat.

Il sistema Chromelock permette il bloccaggio sicuro della porta anche durante l'uso intensivo ed estremo della vostra imbarcazione.

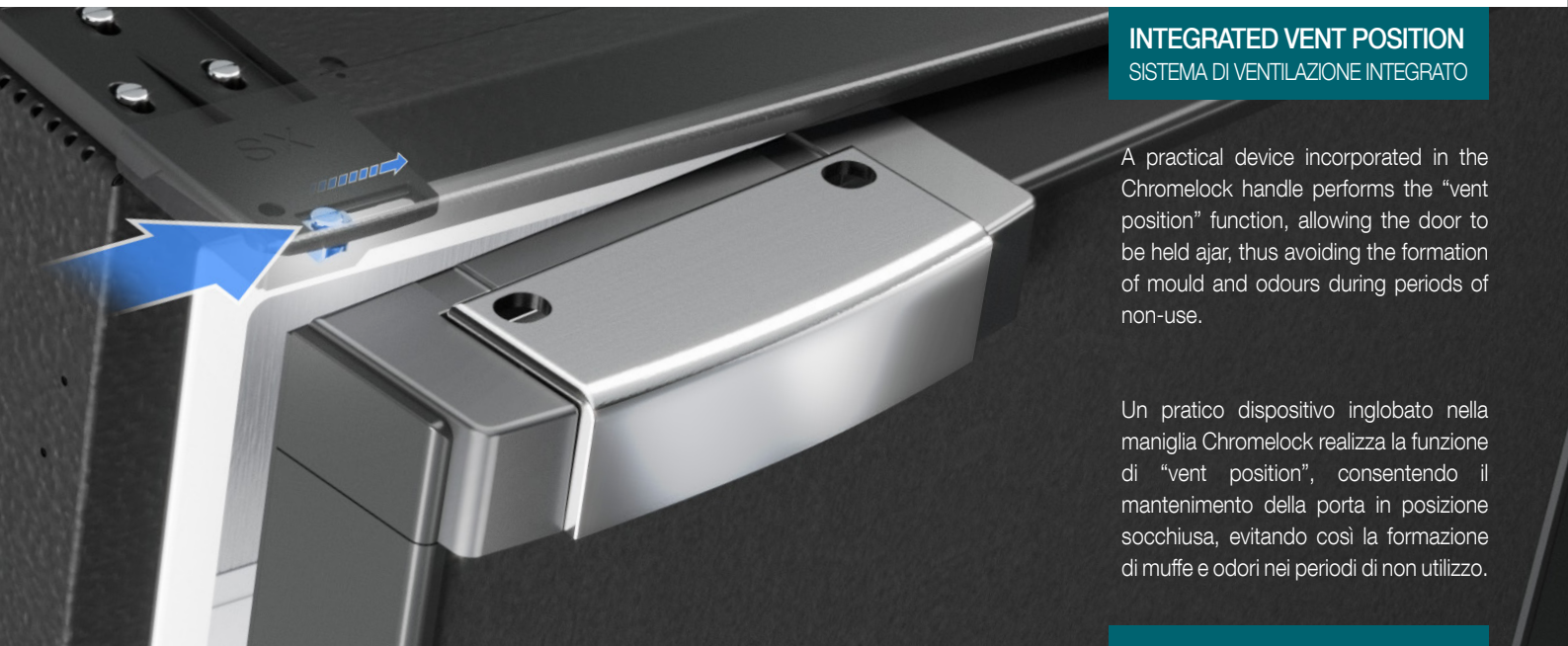

INTEGRATED VENT POSITION SISTEMA DI VENTILAZIONE INTEGRATO

A practical device incorporated in the Chromelock handle performs the "vent position" function, allowing the door to be held ajar, thus avoiding the formation of mould and odours during periods of non-use.

Un pratico dispositivo inglobato nella maniglia Chromelock realizza la funzione di "vent position", consentendo il mantenimento della porta in posizione socchiusa, evitando così la formazione di muffe e odori nei periodi di non utilizzo.

STANDARD



Double door colouring

DOPPIA COLORAZIONE DELLA PORTA

The series is available in light grey or black, to best respond to the customisation needs of your boat interiors.

La serie è disponibile in colorazione grigio perla o in colorazione nera, per una ottimale personalizzazione dell'ambiente interno della vostra imbarcazione.



BLACK

Black matte soft touch panel.
Pannello nero opaco effetto soft touch.



LIGHT GREY

Light grey glossy panel.
Pannello grigio perla effetto lucido.



Replaceable finishing panel

PANNELLO DI FINITURA SOSTITUIBILE



Finishing panels from 0.8 mm to 3.0 mm thick. Replace the panel quickly and easily using (1) interlocking flange, without the use of tools and screws.

Pannelli di finitura con spessori da 0,8 mm. a 3,0 mm. Sostituzione del pannello facile e veloce tramite (1) profilo ad incastro, senza l'uso di utensili e viti.

**FRIDGE + FREEZER**
FRIGORIFERO + FREEZER**FRIDGE**
FRIGORIFERO**DRAWER**
CASSETTO**OPTIONAL** (Mounting flange / Profilo di fissaggio)**Door Inside**
PORTA A FILO INTERNO**Door Outside**
PORTA A FILO ESTERNO

The entire series can be installed by means of a mounting flange (optional), which by simply sliding it forward or back, allows both the totally built-in version (door inside) and the partially built-in version (door outside).

Tutta la serie ha la possibilità di essere installata mediante un profilo di fissaggio (optional), che permette tramite il suo semplice scorrimento in avanti o indietro sia la versione a incasso totale (door inside) che quella a incasso parziale (door outside).

**Remotable cooling unit**
UNITÀ DI REFRIGERAZIONE REMOTABILE

The remotable external cooling unit offers added available volume inside the refrigerator. In addition, it expands the installation possibilities in terms of functionality, efficiency and soundproofing.

L'unità di refrigerazione esterna remotabile permette di avere maggior volume a disposizione all'interno del frigorifero. Inoltre, espande le possibilità di installazione, sia in termini di funzionalità che di efficienza e insonorizzazione.

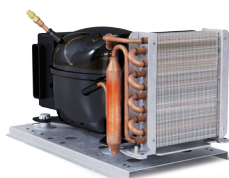
Up to 1,5
FINO A mt.**Dual electronic control**
CENTRALINA BIVALENTE12/24 Vdc 100/240 Vac
50/60 Hz



DP2600i CHR

Total volume Capacità totale	230 lt.
Freezer compartment Vano freezer	60 lt.
Net weight Peso netto	58,5 kg.
Power supply and nominal consumption Alimentazione e consumo nominale	12/24 Vdc 65 W

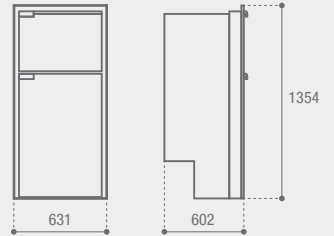

OPTIONAL
Fridge 12/24Vdc
Freezer 100-240Vac



DP150i CHR

Total volume Capacità totale	150 lt.
Freezer compartment Vano freezer	30 lt.
Net weight Peso netto	40,6 kg.
Power supply and nominal consumption Alimentazione e consumo nominale	12/24 Vdc 65 W

Dimension without fitting frame (optional)
Dimensioni senza profilo di fissaggio (optional)

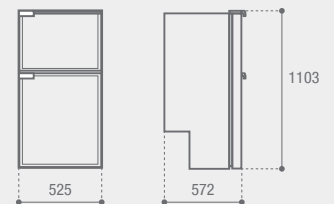

OPTIONAL
Fridge 12/24Vdc
Freezer 100-240Vac



C115i - C115iA CHR

Total volume Capacità totale	115 lt.
Freezer compartment Vano freezer	17,1 lt.
Net weight Peso netto	21,2 kg.
Power supply and nominal consumption Alimentazione e consumo nominale	12/24 Vdc 45 W

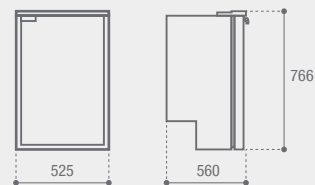

C90i CHR

Total volume Capacità totale	90 LT.
Freezer compartment Vano freezer	9,1 LT.
Net weight Peso netto	20,6 kg.
Power supply and nominal consumption Alimentazione e consumo nominale	12/24 Vdc 45 W

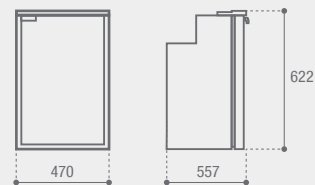

H max
280 mm.



C90DW CHR

Total volume Capacità totale	90 lt.
Freezer compartment Vano freezer	9,1 lt.
Net weight Peso netto	23,6 kg.
Power supply and nominal consumption Alimentazione e consumo nominale	12/24 Vdc 45 W

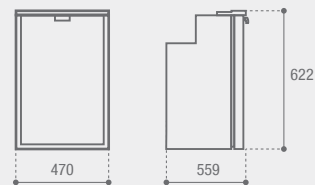



C85i - C85iA CHR

Total volume Capacità totale	85 lt.
Freezer compartment Vano freezer	12,8 lt.
Net weight Peso netto	23,3 kg.
Power supply and nominal consumption Alimentazione e consumo nominale	12/24 Vdc 45 W

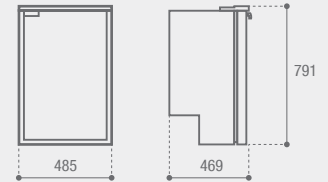

C62i CHR

Total volume Capacità totale	62 lt.
Freezer compartment Vano freezer	4,5 lt.
Net weight Peso netto	16,8 kg.
Power supply and nominal consumption Alimentazione e consumo nominale	12/24 Vdc 40 W

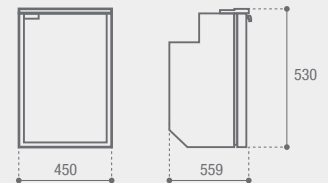

C60i - C60iA CHR

Total volume Capacità totale	60 lt.
Freezer compartment Vano freezer	10,2 lt.
Net weight Peso netto	18,6kg.
Power supply and nominal consumption Alimentazione e consumo nominale	12/24 Vdc 40 W

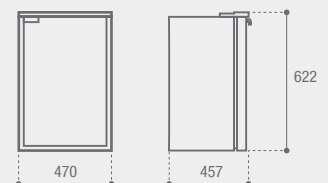



Fridge
Freezer

OPTIONAL
12/24Vdc
100-240Vac

C51i CHR

Total volume Capacità totale	51 lt.
Freezer compartment Vano freezer	3,6 lt.
Net weight Peso netto	16 kg.
Power supply and nominal consumption Alimentazione e consumo nominale	12/24 Vdc 40 W

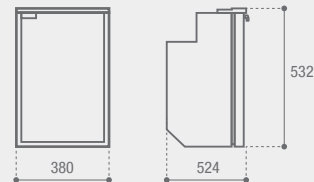

H max
250 mm.



Fridge
Freezer

OPTIONAL
12/24Vdc
100-240Vac

C51DW CHR

Total volume Capacità totale	51 lt.
Freezer compartment Vano freezer	3,6 lt.
Net weight Peso netto	19 kg.
Power supply and nominal consumption Alimentazione e consumo nominale	12/24 Vdc 40 W

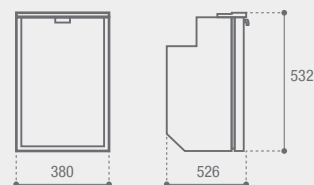

OPTIONAL
Fridge

Fridge
Freezer

OPTIONAL
12/24Vdc
100-240Vac

C50i CHR

Total volume Capacità totale	51 lt.
Freezer compartment Vano freezer	3,6 lt.
Net weight Peso netto	15,7 kg.
Power supply and nominal consumption Alimentazione e consumo nominale	12/24 Vdc 40 W

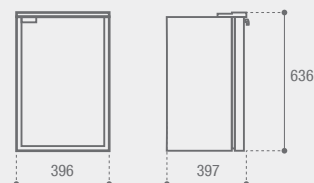

OPTIONAL
Fridge

Fridge
Freezer

OPTIONAL
12/24Vdc
100-240Vac

C39i CHR

Total volume Capacità totale	39 lt.
Freezer compartment Vano freezer	3,6 lt.
Net weight Peso netto	16 kg.
Power supply and nominal consumption Alimentazione e consumo nominale	12/24 Vdc 31 W

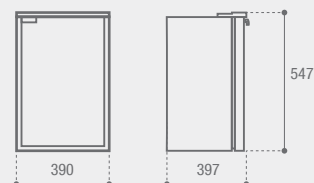



C130L - C130LA CHR

Total volume Capacità totale	130 lt.
Freezer compartment Vano freezer	17,1 lt.
Net weight Peso netto	25,2 kg.
Power supply and nominal consumption Alimentazione e consumo nominale	12/24 Vdc 45 W

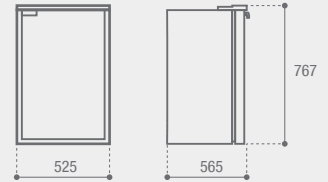

C95L - C95LA CHR

Total volume Capacità totale	95 lt.
Freezer compartment Vano freezer	12,8 lt.
Net weight Peso netto	22,3 kg.
Power supply and nominal consumption Alimentazione e consumo nominale	12/24 Vdc 45 W

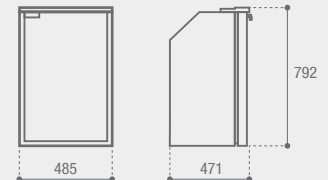

C75L - C75LA CHR

Total volume Capacità totale	75 lt.
Freezer compartment Vano freezer	10,2 lt.
Net weight Peso netto	18,6 kg.
Power supply and nominal consumption Alimentazione e consumo nominale	12/24 Vdc 40 W

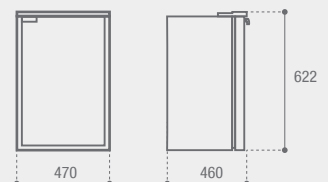



 H max
330 mm.



C75DW CHR

Total volume Capacità totale	75 lt.
Freezer compartment Vano freezer	10,2 lt.
Net weight Peso netto	21,6 kg.
Power supply and nominal consumption Alimentazione e consumo nominale	12/24 Vdc 40 W

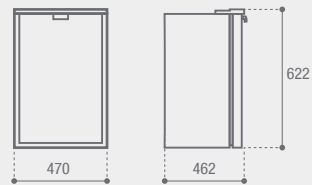

C42L CHR

Total volume Capacità totale	42 lt.
Freezer compartment Vano freezer	3,6 lt.
Net weight Peso netto	15 kg.
Power supply and nominal consumption Alimentazione e consumo nominale	12/24 Vdc 31 W

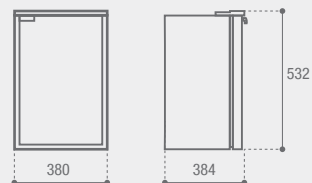

 H max
420 mm.



C42DW CHR

Total volume Capacità totale	42 lt.
Net weight Peso netto	18 kg.
Power supply and nominal consumption Alimentazione e consumo nominale	12/24 Vdc 31 W

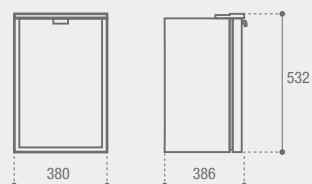

C25L CHR

Total volume Capacità totale	25 lt.
Net weight Peso netto	12 kg.
Power supply and nominal consumption Alimentazione e consumo nominale	12/24 Vdc 34 W

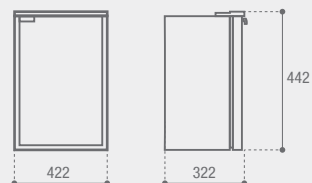

TOP LOADING SERIES



TOP LOADING

FRIDGES AND FREEZERS

POZZETTO

FRIGORIFERI E FREEZER

Available models Modelli disponibili	Total volume Capacità totale
	LT.
TL43	40
TL35RF	34
TL20RF	20
TL37L - T37LA	37
TL37BT	37
TL40L	40
TL160	160
TL180	180



Make the most of your space

USA AL MEGLIO IL TUO SPAZIO

Built-in fridges/freezers with top opening (top loading) are designed to be specially housed in confined spaces.

They offer excellent performance even in extreme temperature conditions and, due to their low energy absorption, are particularly suitable for operation with solar energy.

I frigoriferi/freezer da incasso con apertura dall'alto (a pozzetto) sono progettati per essere alloggiati appositamente in spazi ristretti.

Offrono eccellenti prestazioni anche in condizioni di temperature estreme e, per il loro basso assorbimento di energia, sono particolarmente indicati per il funzionamento con energia solare.

TOP LOADING FRIDGES AND FREEZERS

POZZETTO FRIGORIFERI E FREEZER





Small products, great performances

PICCOLI PRODOTTI, GRANDI PRESTAZIONI

The new 40-litre model (TL43) boasts significant operating characteristics: it can operate for more than 3 days, in a continuous cycle, connected to a battery of only 100 A/h. Equipped with two food storage trays with different capacities, it allows the storage of both small and large bottles in the space below.

The digital membrane LED thermostat, internal LED light and remote cooling unit make it an unprecedented top-of-the-range product.

The TL20RF model, with a 20-litre capacity and external cooling unit, differs in terms of the interior made completely of stainless steel.

The series includes the TL37L model with stainless steel interior and the TL40L model with thermoformed plastic interior, combined with the visible resin finish of the cabinet, making it suitable for built-in installation only.

Il nuovo modello da 40 litri (TL43) raggiunge delle caratteristiche di funzionamento davvero interessanti: può funzionare per oltre 3 giorni, a ciclo continuo, collegato ad una batteria di soli 100 A/h. Dotato di due vaschette per la conservazione del cibo con capienze differenziate, consente lo stivaggio di bottiglie sia piccole che grandi nello spazio sottostante. Il termostato digitale LED a membrana, la luce interna LED e l'unità refrigerante remotabile ne configurano un top di gamma senza precedenti.

Il modello TL20RF con capacità di 20 litri e unità refrigerante esterna si differenzia per l'interno completamente in acciaio inox.

La serie include il modello TL37L con l'interno in acciaio inox e il modello TL40L con l'interno in materiale plastico termoformato e la finitura con resina a vista del mobile che lo rende adatto per le sole installazioni ad incasso.



FRIDGE + FREEZER

FRESH AND FROZEN
FOOD AND BEVERAGE

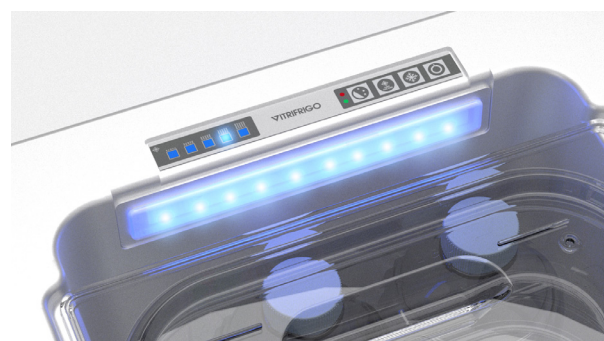



Cools faster, Lasts longer

RAFFREDDA PIÙ VELOCEMENTE, DURA PIÙ A LUNGO

Temperature control with Innovative Membrane LED Digital thermostat
Controllo della temperatura con nuovo termostato LED a membrana



TURBO MODE Fast chill set point temperature
Veloce raggiungimento della temperatura impostata



NIGHT MODE Lowest noise level and reduced consumption during night time
Funzione di riduzione del rumore e del consumo energetico



LED LIGHT High bright internal Led light system
Illuminazione interna a Led ad alta luminosità



EASY FIX Inside out fixings and concealed lid fixings for easy installation
Fissaggi interni nascosti per una facile ed elegante installazione



RE-SEAL Removable seal and easy replacement
Guarnizione rimovibile e facile sostituzione



IDEAL TO RUN FROM SOLAR POWER 24/7

IDEALE PER UN FUNZIONAMENTO H24 CON ALIMENTAZIONE A CELLE SOLARI



SAVING YOUR MONEY

RISPARMIO ECONOMICO



SAVING THE ENVIRONMENT

SALVAGUARDIA DELL'AMBIENTE



ULTRALIGHT

14,5 KG.
ULTRALEGGERO

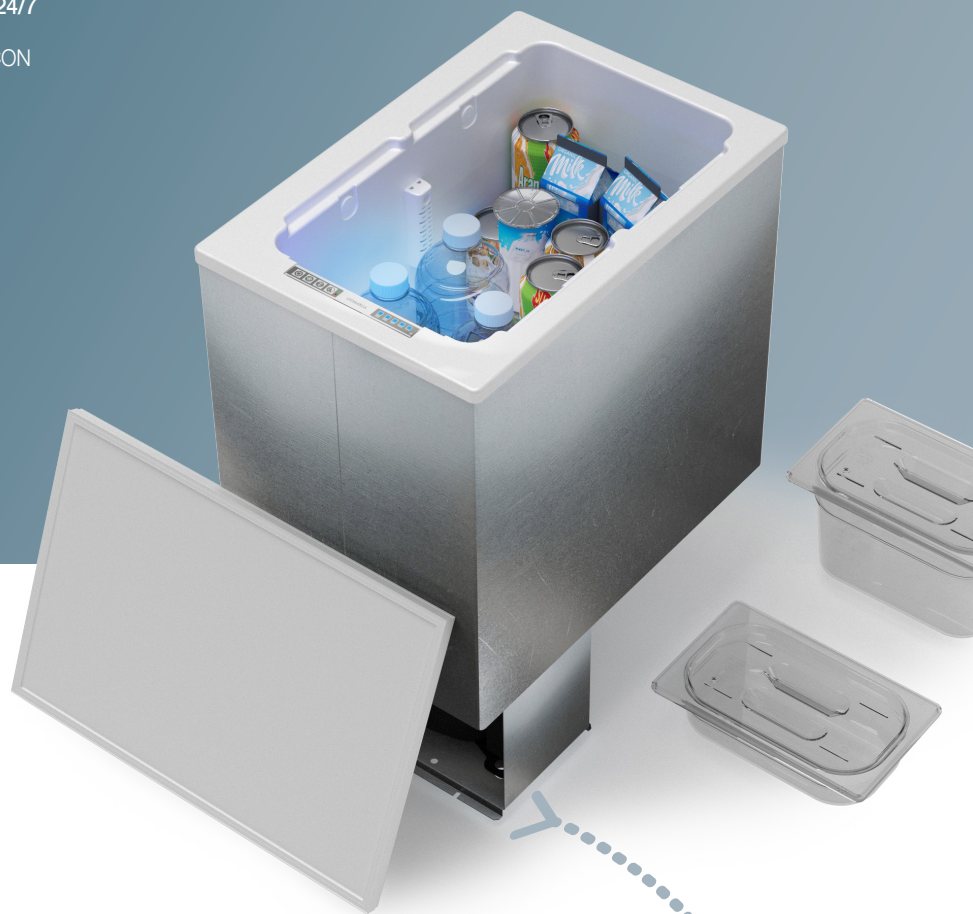

3 + DAYS

RUNS FOR 3 OR MORE DAYS ON A 100 A/H LEISURE BATTERY

AUTONOMIA DI OLTRE 3 GIORNI
CON UNA NORMALE BATTERIA DI SOLI 100 A/H

OPTIONAL



Remotable cooling unit

UNITÀ DI REFRIGERAZIONE REMOTABILE

The remotable external cooling unit offers added available volume inside the refrigerator. In addition, it expands the installation possibilities in terms of functionality, efficiency and soundproofing.

L'unità di refrigerazione esterna remotabile permette di avere maggior volume a disposizione all'interno del frigorifero. Inoltre, espande le possibilità di installazione, sia in termini di funzionalità che di efficienza e insonorizzazione.

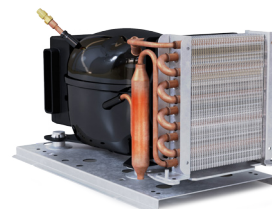

UP TO FINO A 1,5 mt.





Smart storage system

GESTIONE DELLO SPAZIO INTELLIGENTE

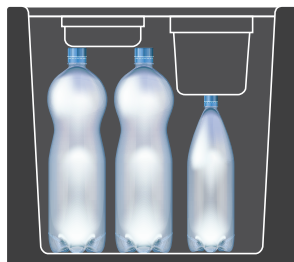

H max
265 mm.

H max
200 mm.



TL43 is equipped with two different depths removable food containers, to allow the storage in the underlying volume of bottles with different capacities.

TL43 è equipaggiato con due contenitori amovibili per il cibo a profondità differenziata, in modo da permettere lo stivaggio nel volume sottostante di bottiglie con diversa capacità.

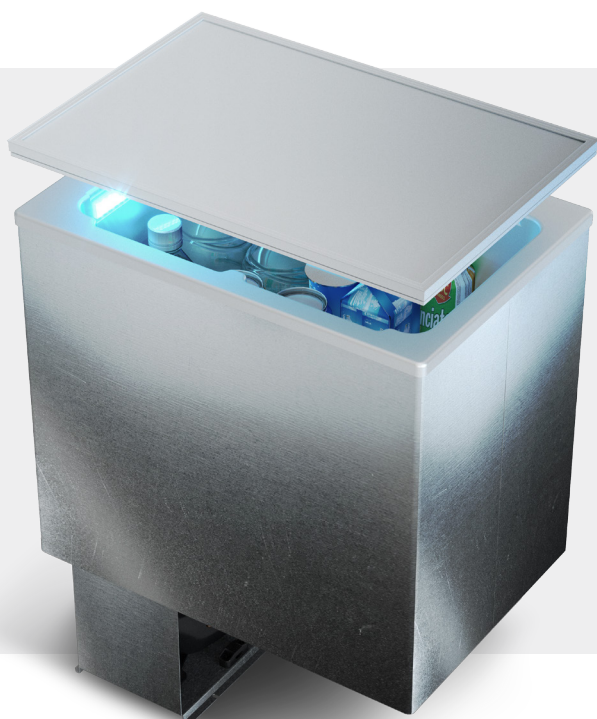

TL43

Total volume Capacità totale	40 lt.
Net weight Peso netto	14,5 kg.
Power supply and nominal consumption Alimentazione e consumo nominale	12/24 Vdc 45 W



+10 -10

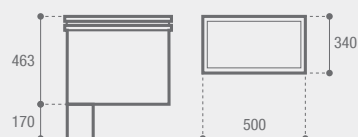

External drain

SCARICO ESTERNO

Condensate conveyor outside the vehicle.

Convogliatore della condensa all'esterno del veicolo.



Dual electronic control

CENTRALINA BIVALENTE

12/24 Vdc 100-240 Vac - 50/60 Hz



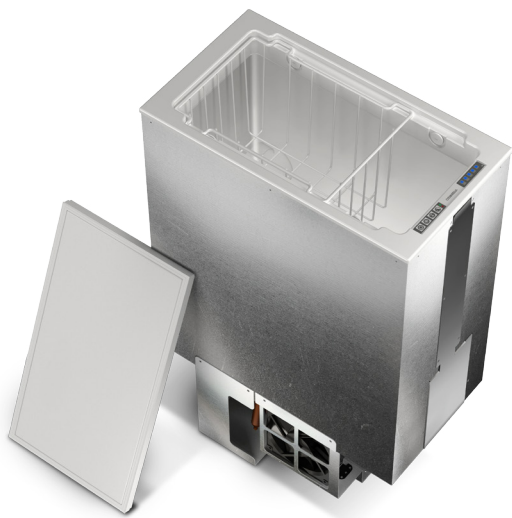

D-POWER OPTIONAL
12/24Vdc
100-240Vac

TL35RF

NEW

Total volume Capacità totale	34 lt.
Net weight Peso netto	15 kg.
Power supply and nominal consumption Alimentazione e consumo nominale	12/24 Vdc 28 W

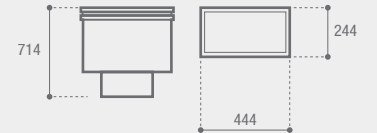

TL20RF

Total volume Capacità totale	20 lt.
Net weight Peso netto	17 kg.
Power supply and nominal consumption Alimentazione e consumo nominale	12/24 Vdc 28 W
Internal temperature at 25°C ambient temperature Temperatura interna a 25°C ambiente	+4 °C

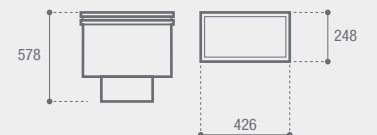

TL37L - T37LA

Total volume Capacità totale	37 lt.
Net weight Peso netto	15 kg.
Power supply and nominal consumption Alimentazione e consumo nominale	12/24 Vdc 45 W
Internal temperature at 25°C ambient temperature Temperatura interna a 25°C ambiente	+4 °C

Available also
as freezer version
Disponibile anche
in versione congelatore

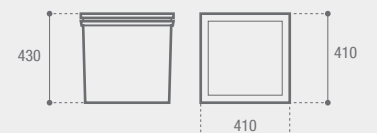

D-POWER OPTIONAL
12/24Vdc
100-240Vac



D-POWER OPTIONAL
12/24Vdc
100-240Vac

TL40L

Total volume Capacità totale	40 lt.
Net weight Peso netto	10 kg.
Power supply and nominal consumption Alimentazione e consumo nominale	12/24 Vdc 31 W
Internal temperature at 25°C ambient temperature Temperatura interna a 25°C ambiente	+4 °C

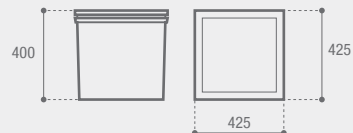

D-POWER OPTIONAL
12/24Vdc
100-240Vac

TL160RF TL160BT

Total volume Capacità totale	160 lt.
Net weight Peso netto	29 kg.
Power supply and nominal consumption Alimentazione e consumo nominale	12/24 Vdc 43 W
Internal temperature at 25°C ambient temperature Temperatura interna a 25°C ambiente	TL 160RF +4 °C TL 160BT -12 °C

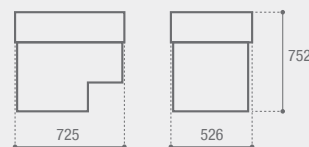

D-POWER OPTIONAL
12/24Vdc
100-240Vac

TL180RF

Total volume Capacità totale	180 lt.
Net weight Peso netto	39 kg.
Power supply and nominal consumption Alimentazione e consumo nominale	12/24 Vdc 43 W
Internal temperature at 25°C ambient temperature Temperatura interna a 25°C ambiente	+4 °C

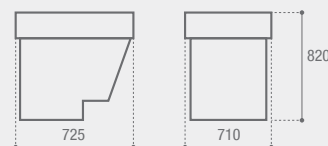

FREEZER SERIES



FREEZERS

CONGELATORI

Available models * Modelli disponibili *	Total volume Capacità totale
	LT.
C110BT CHR	108
C55BT CHR	56
C35BT CHR	33
C30BT CHR	30

* Chromelock series availability is continuously updated: please contact us at sales@vitfrigo.com

* La disponibilità della serie Chromelock è in continua evoluzione: contattateci per gli ultimi aggiornamenti a sales@vitfrigo.com



1, 2, or 3 freezer compartments

CONGELATORI AD 1, 2 O 3 VANI DEDICATI

Vitrifigo freezers are equipped with remote cooling units (to be installed in ventilated areas) with stainless steel or aluminium interiors and evaporators installed within the box.

Congelatori con gruppo refrigerante esterno (da installarsi in vano sufficientemente ventilato), con interno in acciaio inox o alluminio ed evaporatore a scomparsa (all'interno dell'isolamento).



D-POWER OPTIONAL
12/24Vdc
100-240Vac

C110BT CHR

Total volume Capacità totale	108 lt.
Net weight Peso netto	34,2 kg.
Power supply and nominal consumption Alimentazione e consumo nominale	12/24 Vdc 52 W

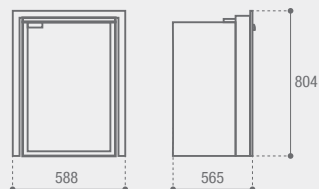

D-POWER OPTIONAL
12/24Vdc
100-240Vac

C55BT CHR

Total volume Capacità totale	56 lt.
Net weight Peso netto	26,1 kg.
Power supply and nominal consumption Alimentazione e consumo nominale	12/24 Vdc 38 W

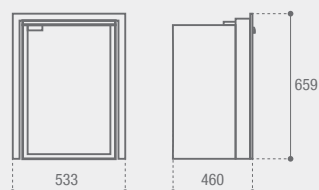

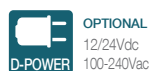

C35BT CHR

Total volume Capacità totale	33 lt.
Net weight Peso netto	19,3 kg.
Power supply and nominal consumption Alimentazione e consumo nominale	12/24 Vdc 38 W

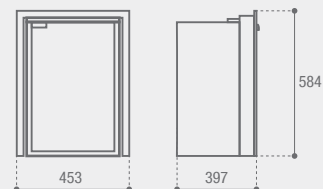

Remotable cooling unit

UNITÀ DI REFRIGERAZIONE REMOTABILE

Up to **1,5**
FINO A **mt.**

The remotable external cooling unit offers added available volume inside the refrigerator. In addition, it expands the installation possibilities in terms of functionality, efficiency and soundproofing.

L'unità di refrigerazione esterna remotabile permette di avere maggior volume a disposizione all'interno del frigorifero. Inoltre, espande le possibilità di installazione, sia in termini di funzionalità che di efficienza e insonorizzazione.

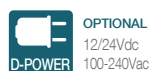
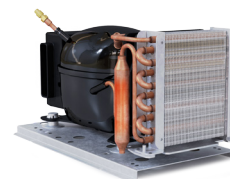

C30BT CHR

Total volume Capacità totale	30 lt.
Net weight Peso netto	22,2 kg.
Power supply and nominal consumption Alimentazione e consumo nominale	12/24 Vdc 38 W

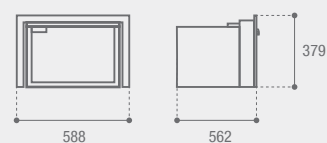

HOME COMFORT



COMBINED

FRIDGES AND FREEZERS

COMBINATI

FRIGORIFERI E FREEZER

Available models Modelli disponibili	Total volume Capacità totale
	LT.
C270DP	271
C220DP	220
C190MP	190
C150MP	125



Feel at home

SENTIRSI A CASA

Dedicated to large boats, the combined fridge-freezers, both single-door and double-door, solve any need for large refrigerated spaces on-board. Ideal for anyone seeking the practicality, functionality and convenience of their home refrigerator.

Dedicati ai natanti di grandi dimensioni, i combinati frigo-freezer sia monoporta che a doppia porta risolvono qualsiasi esigenza di avere a bordo ampi spazi refrigerati. Per tutti coloro che non vogliono farsi mancare la praticità, la funzionalità e la comodità del proprio frigorifero domestico.

Fresh and crisp fruit and vegetables

FRUTTA E VERDURA FRESCHE E CROCCANTI

The perfect control of humidity levels, together with minimised temperature variations inside the fruit and vegetable drawer, mean that stored food is kept fresh and crisp.

Il perfetto controllo dei livelli di umidità, unitamente a variazioni di temperatura minimizzate all'interno del cassetto frutta e verdura, fanno sì che si riescano a conservare alimenti sempre freschi e croccanti.

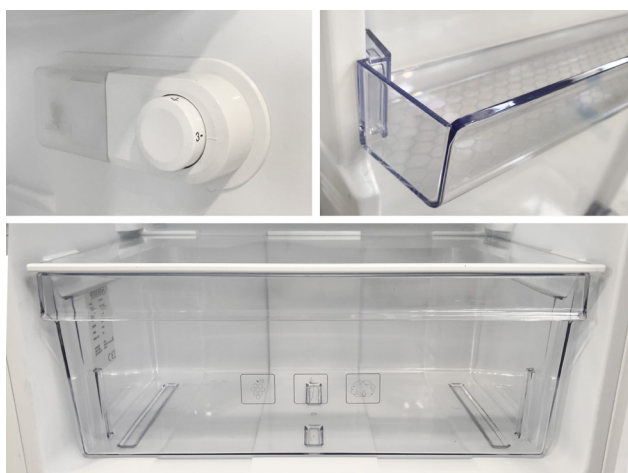

OPTIONAL Dual electronic control

D-POWER CENTRALINA BIVALENTE

12/24 Vdc 100-240 Vac
50/60 Hz



Perfect internal sanitisation

PERFETTA IGIENIZZAZIONE INTERNA

The interior walls of the refrigerators are treated by a natural system to inhibit the onset of mould and bacteria and to protect the integrity of food, while the innovative gaskets ensure the protection of even the outermost areas of the refrigerator.

Le pareti interne dei frigoriferi sono trattate mediante un sistema naturale per inibire l'insorgere di muffe e batteri e proteggere l'integrità degli alimenti, mentre le innovative guarnizioni assicurano



High potential lighting

ILLUMINAZIONE AD ALTO POTENZIALE

The internal lighting system includes the standard installation of a very bright top light making sure all parts of the refrigerator are properly lit.

Il sistema di illuminazione interna prevede l'installazione di serie di una plafoniera ad alta luminosità che garantisce il raggiungimento della luce in qualsiasi punto del frigorifero.



C270DP

Total volume Capacità totale	271 lt.
Freezer compartment Vano freezer	78 lt.
Net weight Peso netto	56 kg.
Power supply and nominal consumption Alimentazione e consumo nominale	12/24 Vdc 61 W

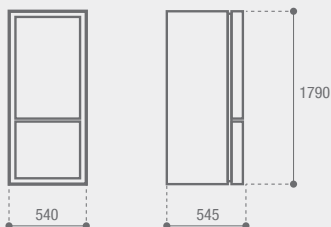

OPTIONAL
12/24Vdc
100-240Vac



C220DP

Total volume Capacità totale	220 lt.
Freezer compartment Vano freezer	44 lt.
Net weight Peso netto	43,5 kg.
Power supply and nominal consumption Alimentazione e consumo nominale	12/24 Vdc 56 W

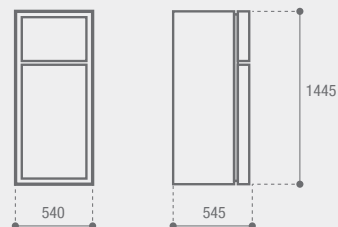
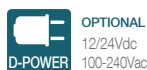

C190MP

Total volume Capacità totale	200 lt.
Freezer compartment Vano freezer	19 lt.
Net weight Peso netto	39 kg.
Power supply and nominal consumption Alimentazione e consumo nominale	12/24 Vdc 56 W

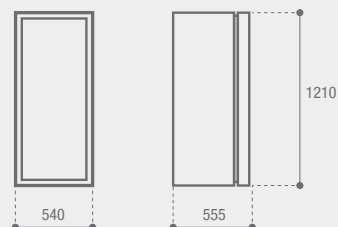

C150MP

Total volume Capacità totale	125 lt.
Freezer compartment Vano freezer	15 lt.
Net weight Peso netto	29 kg.
Power supply and nominal consumption Alimentazione e consumo nominale	12/24 Vdc 58 W

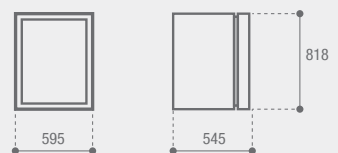
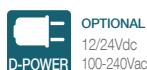

WINECELLARS



WINECELLARS

CANTINETTE

Available models
Modelli disponibili

Total volume
Capacità totale

DCW 95

32

DCW 62

18

DCW 46

10



For for real connoisseurs

PER VERI INTENDITORI

Entertaining friends and family is a high priority aboard and it is a special status to pay considerable attention to the proper preservation of your wine collection.

Intrattenere gli amici e la famiglia rappresenta spesso un'alta priorità a bordo e rappresenta uno status speciale dedicare notevole attenzione alla giusta conservazione della propria collezione di vini.



IDEAL TEMPERATURE

The available wine cellar models have a capacity of 10, 18 or 32 bottles, with darkened glass (protection against UV rays) and brushed stainless steel finish. Ideal for storing bottles of wine even for long periods.

The temperature settings are adjusted by digital thermostat (+4°C +18°C).

TEMPERATURA IDEALE

I modelli di cantinette disponibili hanno capacità di 10, 18 e 32 bottiglie, anta con vetro oscurato (protezione raggi UV) e finitura in acciaio inox spazzolato.

Ideali per conservare le bottiglie di vino anche per lunghi periodi, hanno la regolazione della temperatura mediante termostato digitale (+4°C +18°C).



DCW95 - DCW62 - DCW46

	DCW 95	DCW 62	DCW 46
Total volume Capacità totale	lt. 95	62	46
Net weight Peso netto	kg. 26	21	18
Power supply and nominal consumption Alimentazione e consumo nominale	12/24Vdc 100-240Vac 50/60Hz W 42 42 42		
Bottle number Numero bottiglie	32	18	10

Non-reversible door / Porta non reversibile

DCW95

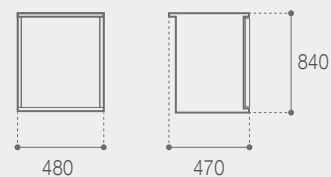

DCW62

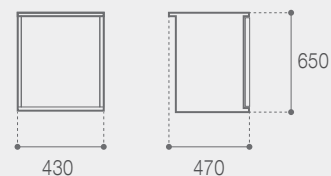

DCW46

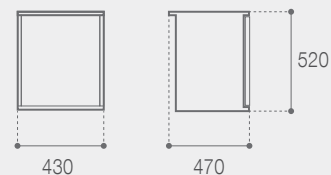

H max: 315 mm.
Ø max: 76 mm.



PORTABLES



PORTABLES

FRIDGES AND FREEZERS

PORTATILI

FRIGORIFERI E FREEZER

Available models Modelli disponibili	Total volume Capacità totale
---	---------------------------------

C65L - C65D	65 lt.
C41L - C41D	41 lt.
C29M - C29D	29 lt.

VFREE SERIES

VF65P	65 lt.
VF55P	55 lt.
VF45P	45 lt.
VF35P	35 lt.
VF16P	16 lt.



Superior portability

PORTABILITÀ DI LIVELLO SUPERIORE

The portable refrigerators and freezers by Vitrifrigo offer excellent portability features, both in terms of reduced consumption and operational silence, and in terms of range and speed of reaching the desired temperature. Efficiency, versatility and compactness: with capacities ranging from 16 to 65 litres, they are a valid alternative to a traditional fridge/freezer.

I frigoriferi e freezer portatili Vitrifrigo offrono eccellenti caratteristiche di portabilità, sia in consumi ridotti e di silenziosità operativa che in termini di range e velocità di raggiungimento della temperatura desiderata. Efficienza, versatilità e compattezza: con capacità che vanno da 16 fino a 65 litri, rappresentano una valida alternativa ad un frigo/freezer di tipo tradizionale.



Bring them everywhere!

PORTATELI OVUNQUE!

Portable refrigerators provide foldable handles for easy carrying. Handles are installed, using sturdy metal pins, to avoid sudden breakage.

Comfort and safety are, once more, an indispensable combination.

I frigoriferi portatili sono dotati di serie di maniglie per un agevole trasporto.

Per i modelli con maniglie pieghevoli, il fissaggio e la rotazione di queste ultime avviene mediante robusti perni in acciaio che mettono al riparo da rotture improvvise. Comfort e sicurezza sono, ancora una volta, un binomio indissolubile.



Temperature under control

TEMPERATURA SOTTO CONTROLLO

Depending on the type of portable refrigerator, there are thermostat choices for the maintenance of desired internal temperatures.

A seconda della tipologia di frigorifero portatile è possibile scegliere la soluzione che più si addice alle esigenze personali, per mantenere la temperatura interna del frigorifero costantemente monitorata.

(a) Termostato meccanico / Mechanical thermostat

(b) Termostato a Led / LED thermostat

(c) Termostato digitale / Digital thermostat



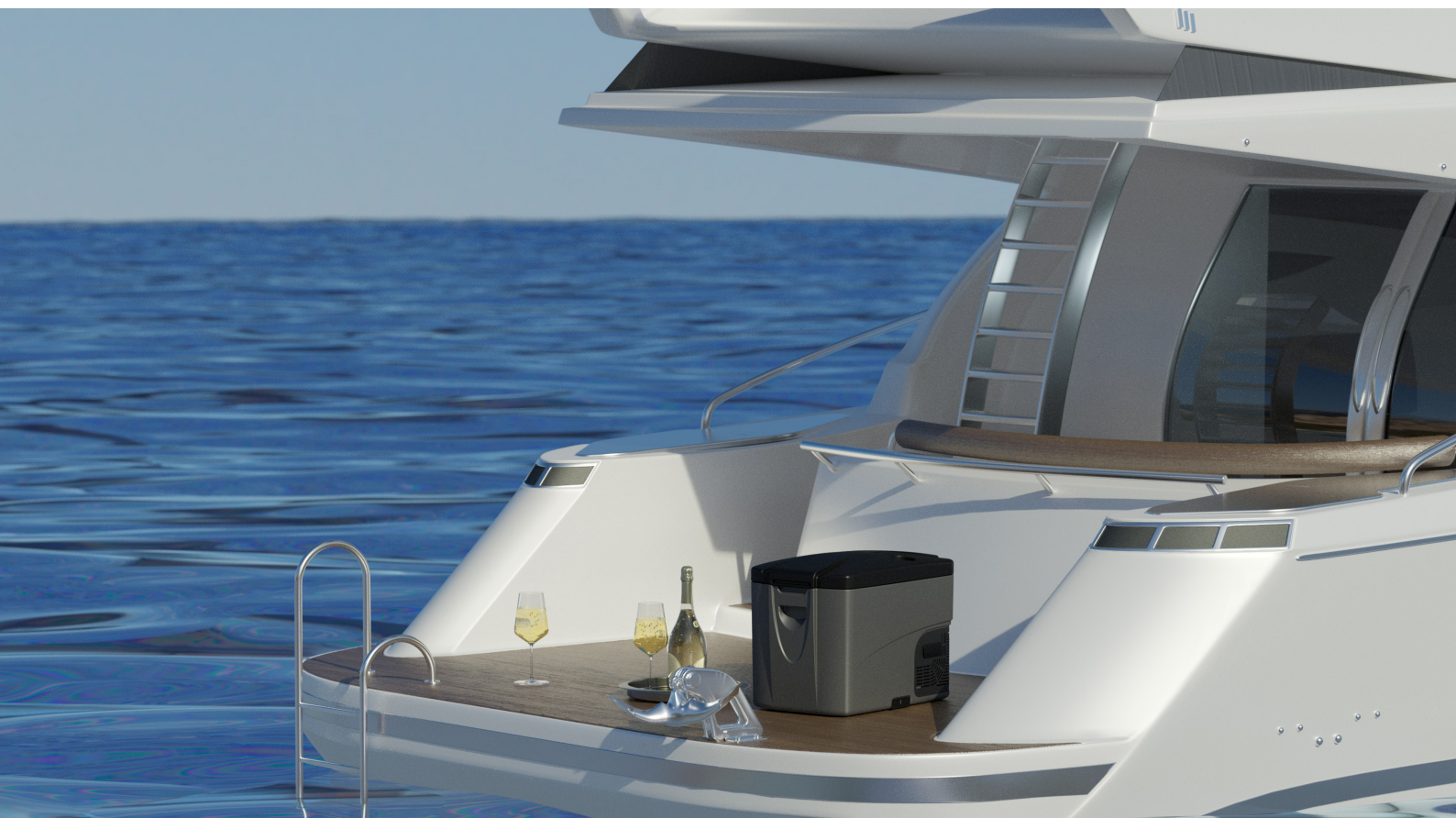

Organize your free time

ORGANIZZATE IL VOSTRO TEMPO LIBERO

Portable refrigerators are equipped with a removable coated wire basket, useful for easily loading and removing food and drinks.

The standard locking bracket allows to keep the refrigerator in place while underway (except for C65).

A 12Vdc cord is supplied for connecting the refrigerator to the car battery.

I frigoriferi portatili sono dotati di serie di un pratico cestello interno removibile a fili d'acciaio, estremamente utile per introdurre o estrarre facilmente tutto il contenuto del frigorifero.

La staffa di fissaggio in dotazione standard dà la possibilità di ancorare saldamente e velocemente il frigorifero in uno spazio predeterminato (eccetto C65).

In dotazione anche il cavo per l'alimentazione a batteria, con la presa universale per l'accendisigari.

Removable basket - Cestello removibile



Locking bracket - Staffa di fissaggio



12Vdc plug - Presa per alimentazione a 12 Vdc



Internal led light - Luce interna a Led



°C + 10 - 20



C65L - C65D

Total volume Capacità totale	65 lt.
Net weight Peso netto	24 kg.
Power supply and nominal consumption Alimentazione e consumo nominale	12/24 Vdc 45 W

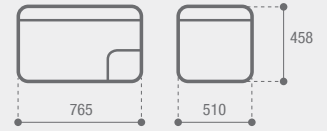

OPTIONAL
12/24Vdc
100-240Vac

C65L - LED thermostat - Termostato a Led
C65D - Digital thermostat - Termostato digitale





°C + 10 - 10



LED



OPTIONAL
12/24Vdc
100-240Vac

C41L - C41D

Total volume Capacità totale	41 lt.
Net weight Peso netto	17 kg.
Power supply and nominal consumption Alimentazione e consumo nominale	12/24 Vdc 43 W

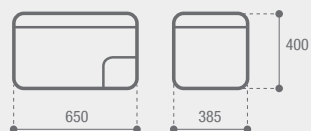

C41L - LED thermostat - Termostato a Led
C41D - Digital thermostat - Termostato digitale



°C + 10 - 15



LED



OPTIONAL
12/24Vdc
100-240Vac

C29M - C29D

Total volume Capacità totale	29 lt.
Net weight Peso netto	15 kg.
Power supply and nominal consumption Alimentazione e consumo nominale	12/24 Vdc 48 W

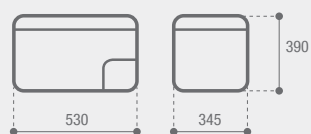

C29M - Mech. thermostat - Termostato mecc.
C29D - Digital thermostat - Termostato digitale

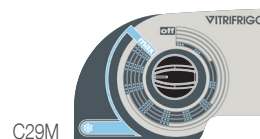

C29M

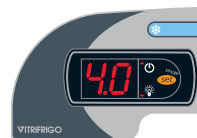

C29D

C29D is available only as 12/24Vdc 100-240Vac 50/60Hz

C29D è disponibile solo in versione 100-240Vac 50/60Hz



PORTABLES

FRIDGES AND FREEZERS

FRIGORIFERI E FREEZERS

PORTATILI





ALL THE CAPACITY YOU NEED

TUTTA LA CAPIENZA CHE TI SERVE

The VFREE series ensures ideal cooling performance even at extremely high ambient temperatures, thanks to the use of state-of-the-art compressors, with extremely low energy consumption. From the smallest of the range, the VF16P featuring 16 litres of lightness, usable in a wide variety of recreational situations, up to the generous VF65P, offering 65 litres, perfectly capable of replacing a traditional type refrigerator, the Vfree series offers refrigeration and freezing from +10 up to -22°C with operation at 12/24 Vdc 100-240Vac 50/60Hz combined with extremely reduced consumption, thereby making it an excellent travel companion even in the presence of a photovoltaic system.

La serie VFREE assicura prestazioni di raffreddamento ideali anche a temperature ambiente estremamente elevate, grazie all'utilizzo di compressori di ultima generazione, a fronte di un consumo energetico estremamente basso. Dal più piccolo della serie, il VF16P, 16 litri di leggerezza, utilizzabile nelle più svariate situazione tipiche del tempo libero, sino al generoso VF65P, un 65 litri, capace di sostituire in maniera perfetta anche un frigorifero di tipo tradizionale, la serie Vfree offre refrigerazione e congelazione da +10 sino a -22 °C con funzionamento a 12/24 Vdc 100-240Vac 50/60Hz a fronte di consumi davvero ridotti, si da farne un compagno di viaggio eccellente anche in presenza di impianto fotovoltaico.





Practicality is not an optional!

LA PRATICITÀ NON È UN OPTIONAL

The VFREE series has been designed to offer maximum practicality in daily use:

- two sturdy handles facilitate lifting and transportation (the VF16P is equipped with a handy strap for carrying on the shoulder);
- the lid can be opened on both sides and, if necessary, is completely removable (with the exception of the VF16P);
- the basket is removable and its internal volume can be compartmentalised to optimise the storage of food and drinks (with the exception of the VF16P);
- a wide range of usable power supplies: from 12/24Vdc to 100-240Vac 50/60Hz;
- the interior lighting with high brightness blue LEDs allows use of the fridge in situations of complete darkness.

La serie VFREE è stata pensata per offrire il massimo della praticità nell'utilizzo quotidiano:

- due robusti maniglioni agevolano il sollevamento e il trasporto (il VF16P ha in dotazione una tracolla per il trasporto a spalla);
- il coperchio è apribile da entrambi i lati e, all'occorrenza, completamente amovibile (ad eccezione del VF16P);
- il cestello è estraibile e il suo volume interno divisibile per ottimizzare lo stivaggio di cibo e bevande (ad eccezione del VF16P);
- un ampio range di alimentazioni utilizzabili: da 12/24Vdc a 100-240Vac 50/60Hz;
- l'illuminazione interna a led azzurrati ad alta luminosità consente l'utilizzo del frigo in situazioni di totale assenza di luce.



Precise and total control

CONTROLLO PRECISO E TOTALE

The digital control panel allows quick access to the functions of the VFREE series: all information regarding the temperature set points are shown on the high brightness LED display.

A convenient USB socket is available for a direct power supply and for the charging of devices such as smartphones, tablets, etc.

In addition, the "Emergency override" function automatically blocks the thermostat in the event of a malfunction, allowing the fridge to operate in complete autonomy.

Il pannello di controllo digitale consente il rapido accesso alle funzioni della serie VFREE: tutte le informazioni relativamente ai set point della temperatura vengono visualizzate sul display led ad alta luminosità.

Disponibile una comoda presa USB per l'alimentazione e la ricarica diretta di dispositivi quali smartphone, tablet, ecc.

Inoltre, la funzione "Emergency override" blocca automaticamente il termostato in caso di malfunzionamento, lasciando che il frigo funzioni in completa autonomia.





Full set of accessories

RICCA DOTAZIONE DI ACCESSORI

The VFREE series has an interior divided into two compartments with varying capacity, thus offering a practical and smart way to contain products that need to be stored fresh.

VF35P - VF45P - VF55P - VF65P

Internal view - vista dell'interno

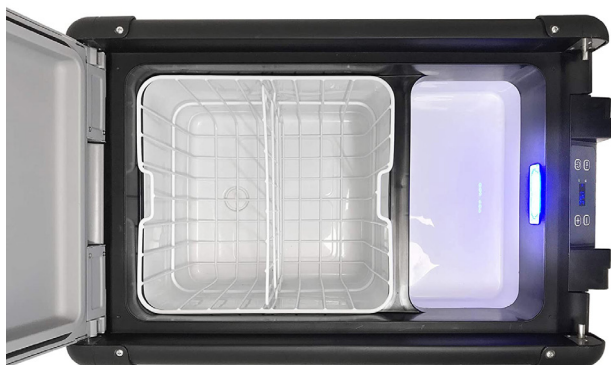

Power supply cable - Cavi per il collegamento alla rete elettrica



La serie VFREE ha l'interno suddiviso in due scomparti a capienza differente, suggerendo così una modalità pratica e intelligente circa l'alloggiamento dei prodotti da conservare al fresco.

VF16P

Internal view - vista dell'interno



shoulder bag - tracolla
external power supply - alimentatore esterno 100-240Vac 50/60Hz





°C + 10 - 22

VF65P



Total volume Capacità totale	65 lt.
Net weight Peso netto	23 kg.
Power supply and nominal consumption Alimentazione e consumo nominale	12/24 Vdc 100-240Vac 50/60Hz 55 W



°C + 10 - 22

VF55P



Total volume Capacità totale	55 lt.
Net weight Peso netto	22 kg.
Power supply and nominal consumption Alimentazione e consumo nominale	12/24 Vdc 100-240Vac 50/60Hz 55 W





°C + 10 - 22



VF45P



Total volume Capacità totale	45 lt.
Net weight Peso netto	20,5 kg.
Power supply and nominal consumption Alimentazione e consumo nominale	12/24 Vdc 100-240Vac 50/60Hz 55 W



°C + 10 - 22



VF35P



Total volume Capacità totale	35 lt.
Net weight Peso netto	19,5 kg.
Power supply and nominal consumption Alimentazione e consumo nominale	12/24 Vdc 100-240Vac 50/60Hz 55 W



°C + 10 - 18



VF16P



Total volume Capacità totale	16 lt.
Net weight Peso netto	8 kg.
Power supply and nominal consumption Alimentazione e consumo nominale	12/24 Vdc 100-240Vac 50/60Hz (*) 45 W

(*) with external power supply
con alimentatore esterno

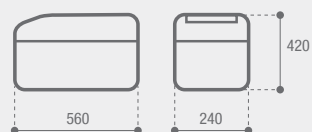

PORTABLES

FRIDGES AND FREEZERS

FRIGORIFERI E FREEZERS

PORTATILI

NEW **V** **PLUS**
FREE



SMART APP CONTROL



Detachable lid with integrated cutting board

Coperchio amovibile con tagliere interno

High brightness white LED light

Luce LED bianca ad alta luminosità



BATTERY - OPTIONAL

15600 mAh detachable lithium ion battery; can keep 4-6 hours of battery life for outdoor use

Batteria agli ioni di litio rimovibile da 15600 mAh; può garantire un'autonomia di 4-6 ore in uso esterno

12/24Vdc 100-240Vac for indoor/outdoor

12/24Vdc 100-240Vac per utilizzo in ambiente interno o esterno

Anti-shake, anti-vibration and incline operation up to 45° angle in short time

Funzionamento antivibrante con inclinazioni fino a 45° in breve tempo



Dual compartment with individual temperature control

Doppio compartimento con temperature indipendenti

Sturdy telescoping handle

Robusto manico telescopico

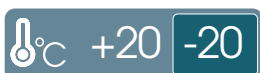

Big wheels

Ruote grandi



ANYWHERE, ANYTIME. FREE

OVUNQUE, SEMPRE. LIBERI

The VFREE PLUS series takes the portable fridge-freezer experience beyond all limits. From the small VFC15, 15 liters to be positioned under the armrest, up to the VFD115: 115 liters divided into two independent compartments with different temperatures, to be comfortably transported by means of sturdy wheels and telescopic handle.

A very cool series, usable by a free app, but above all with incomparable autonomy. Thanks to the high-performance lithium-ion battery (optional), interchangeable and therefore replaceable at any time, and thanks also to the possibility of direct connection with the photovoltaic panel, there is the possibility of an external use without any limit.

La serie VFREE PLUS porta l'esperienza del frigo-freezer portatile oltre ogni limite. Dal piccolo VFC15, 15 litri da posizionarsi sotto il bracciolo, fino al VFD115: 115 litri ripartiti in due scompartimenti indipendenti con temperature differenziate, da trasportarsi comodamente mediante robuste ruote e manico telescopico.

Una serie al passo con i tempi, gestibile mediante app scaricabile gratuitamente, ma soprattutto dotata di un'autonomia senza precedenti. Grazie alla performante batteria agli ioni di litio (optional), intercambiabile e quindi sostituibile in qualunque momento e grazie anche alla possibilità di connessione diretta col pannello fotovoltaico, si ha la possibilità di un utilizzo in esterni senza alcun limite di tempo.



Designed to offer the top!

PENSATA PER OFFRIRE IL MASSIMO!

The VFREE series has been designed to offer maximum practicality in daily use: a range that covers any need, both in terms of capacity and use. Each model is shockproof and designed for an an heavy duty use.

SPECIFIC PARTS: wire storage basket, interior drain plug, LED light, plastic cutting board, cupholder door design, LED display touch control panel.

Allow the compressor speed to be slowed down to increase operational efficiencies (ECO) or increase the compressor speed to provide “quick” cool down times (MAX). Safe to run less than a 45 degrees angle. Noise level reduced to a minimum.



(1) Armrest fridge/freezer
Frigo/freezer da bracciolo



(3) Trolley “dual zone” fridge/freezer
Frigo/freezer a trolley a doppio compartimento



(2) Lightweight portable fridge/freezer
Frigo/freezer portatile leggero

La serie VFREE PLUS è stata pensata per offrire il massimo della praticità nell'utilizzo quotidiano: una gamma che copre qualsiasi esigenza, sia in termini di capacità che di tipologia e ambiente di utilizzo. Tutti i modelli vantano un design antiurto e durevole adatto agli utilizzi più estremi.

PARTI SPECIFICHE: cestello porta filo, tappo di scarico interno, luce LED, tagliere in plastica, design porta portabicchieri, pannello di controllo touch con display LED. Possibilità di rallentare la velocità del compressore per aumentare l'efficienza operativa (ECO) o di aumentarne la velocità per fornire tempi di raffreddamento “rapidi” (MAX). Adatti per funzionamento anche su piano inclinato fino a 45 gradi. Livello di rumorosità ridotto al minimo.



Precise and total control

CONTROLLO PRECISO E TOTALE



The digital control panel allows quick access to the functions of the VFREE PLUS series: all information regarding temperature set points are shown on the high brightness LED digital display. A convenient USB socket is available for a direct power supply and for the charging devices such as smartphones, tablets, etc.. Automatic voltage detection and low voltage automatic power off: the smart battery protection system prevents battery run out, ensuring safe travel.

Il pannello di controllo digitale LCD consente il rapido accesso alle funzioni della serie VFREE PLUS: tutte le informazioni relativamente ai set point della temperatura vengono visualizzate sul display LED ad alta luminosità. Disponibile una comoda presa USB per l'alimentazione e la ricarica diretta di dispositivi quali smartphone, tablet, ecc.. Riconoscimento automatico del voltaggio d'ingresso e spegnimento automatico in caso di batteria al minimo: il sistema intelligente di protezione previene lo scaricamento totale della batteria, offrendo viaggi in piena sicurezza.



External power supply

ALIMENTATORE ESTERNO

100-240Vac external Power Supply. Switchover from tension mains (AC) to battery, mains (DC) is automatic.

Alimentatore esterno 100-240Vac. La commutazione da tensione di rete alternata (CA) a tensione di batteria (CC) è automatica.



12/24Vdc Car Cigarette Lighter Socket Plug Connector

Presa per il collegamento all'accendisigari dell'auto (12/24Vdc).





Full set of accessories

RICCA DOTAZIONE DI ACCESSORI

The VFREE Plus series boasts a rich set of accessories (optional) to extend and improve its use in any situation.

FOLDABLE SOLAR PANEL BAG

BORSA PIEGHEVOLE PER PANNELLI SOLARI.

Light weight, portable and stable output voltage and current, it converts solar energy into electricity and then charges the 15600mAh detachable lithium ion battery (optional). You can connect with a parallel cable more items at the same time to increase the charging speed.

Leggera, portatile e con tensione e corrente stabili in uscita, converte l'energia solare in elettricità e quindi carica la batteria agli ioni di litio rimovibile da 15600 mAh (opzionale). È possibile collegare con un cavo parallelo più elementi contemporaneamente per aumentare la velocità di ricarica.

15.600 mAh DETACHABLE LITHIUM ION BATTERY

BATTERIA AGLI IONI DI LITIO RIMOVIBILE DA 15600 mAh

It can keep 4-6 hours of battery life for outdoor use.

In grado di garantire un'autonomia di 4-6 ore in uso esterno.



SLIDES

GUIDE SCORREVOLI

Heavy duty solid steel, high quality powder coating, zinc coating galvanized never rust. Double side lock-in and lock-out system. 4 straps to secure the fridge. Mountable to any flat surface (*).

Realizzate in acciaio solido per impieghi gravosi, con verniciatura a polvere di alta qualità e rivestimento in ferro zincato anticorrosione. Sistema di lock-in e lock-out su entrambi i lati. Allestite con 4 cinghie per fissare il frigorifero. Montabili su qualsiasi superficie piana (*).



(*) eccetto/except for: VFC15-VFD115

OPTIONAL

La serie VFREE Plus vanta una ricca dotazione di accessori (optional) per estenderne e migliorarne l'utilizzo in qualsiasi situazione.

100/200W Solar Panel 19,5 Vdc - 5,5A



COVER

COPERTURA

Protect your fridge during outdoor use. The cool cover is perfect to add extra insulation and to reduce power consumption. A great protection against excessive movement, dirt, dust, sand and moisture or water splashes.

Proteggi il tuo frigorifero durante l'utilizzo all'aperto. La copertura imbottita è perfetta per aggiungere ulteriore isolamento e ridurre di fatto il consumo energetico. Un'ottima protezione contro movimenti eccessivi, sporco, polvere, sabbia e umidità o schizzi d'acqua.



ARMREST FRIDGE/FREEZER
FRIGO/FREEZER DA BRACCIOLO

°C +20 -18

VFC15



- Leather armrest
Bracciolo in pelle
- Two cups holder
Due portabicchieri
- LED display
Display LED
- Detachable battery
Batteria rimovibile

Total volume Capacità totale	15 lt.
Net weight Peso netto	9,3 kg.
Power supply and nominal consumption Alimentazione e consumo nominale	12/24 Vdc 100-240Vac 50/60Hz 45 W

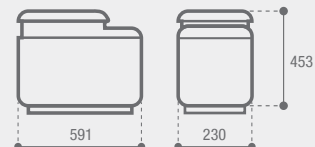

°C +20 -20

VFT30



Total volume Capacità totale	30 lt.
Net weight Peso netto	12,8 kg.
Power supply and nominal consumption Alimentazione e consumo nominale	12/24 Vdc 100-240Vac 50/60Hz 60 W

