

OVERLAND

2023



VITRIFRIGO

MADE IN ITALY





FREEZE YOUR MOMENTS

RENDI UNICO OGNI MOMENTO SPECIALE

INNOVAZIONE, DESIGN E **ECOSOSTENIBILITÀ**:
è la Mission di Vitrifrigo e fa parte di una più ampia
strategia aziendale volta al profondo rispetto
degli obblighi ambientali.

Abbiamo dato vita ad una vera e propria politica
per continuare il nostro impegno a operare come
società responsabile, coinvolgendo direttamente
o indirettamente tutti gli aspetti delle attività
aziendali: progettazione, ingegneria, produzione,
manutenzione dei prodotti o distribuzione delle
loro parti.

In linea con questa politica, Vitrifrigo ha investito
risorse multiple per rinnovare le serie dei prodotti
integrando soluzioni a basso GWP e Gas Naturale.

MAKE EVERY SPECIAL MOMENT UNIQUE

INNOVATION, DESIGN AND **ECO-SUSTAINABILITY**:
This is the fundamental core of Vitrifrigo and is part
of a broader corporate strategy aimed at
respecting environmental obligations.

We have developed a policy to continue our
commitment to operate as a responsible
company. This covers every aspect of the
company's activities, whether directly or
indirectly involved in the design, engineering,
manufacturing, maintenance of our products, or
distribution of their parts.

In line with this policy, Vitrifrigo has invested
multiple resources to renew the ranges of products
with low GWP and Natural Gas solutions.

OVERLAND

Vitrifrigo has as its main objective, designing and producing refrigerators and freezers that can guarantee:

- energy and environmental saving;
- implementation of new technologies;
- efficiency, safety and durability;
- aesthetic and functional design;
- use of innovative materials.

Our products are, for these reasons, in constant evolution.

Vitrifrigo has chosen to keep releasing its paper catalogues, in full awareness that the corresponding digital versions in pdf format, freely downloadable, will always contain in any case all those updates that, for obvious reasons, cannot be added to the print version.

We therefore invite you to stay always updated by downloading them using this QR code.

STAY TUNED



Vitrifrigo ha come obiettivo principale la progettazione e la produzione di frigoriferi e freezer che possano essere a garanzia di:

- risparmio energetico e ambientale;
- implementazione delle nuove tecnologie;
- efficienza, sicurezza e durabilità;
- design estetico e funzionale;
- utilizzo di materiali innovativi.

I prodotti Vitrifrigo sono, per tali ragioni, in continua evoluzione.

Vitrifrigo ha scelto di continuare a rilasciare i propri cataloghi anche nel formato cartaceo, nella piena consapevolezza che le corrispondenti versioni digitali in formato pdf, liberamente scaricabili, conterranno sempre e comunque tutti quegli aggiornamenti che, per ovi motivi, non sono immediatamente apportabili anche sulla carta stampata. Vi invitiamo, quindi, a restare sempre aggiornati, effettuandone il download, mediante questo QR code.

CHROMELOCK SERIES 04



SLIM SERIES 16



HOME COMFORT 24



SPECIAL INSTALLATIONS 30



TOP LOADING 38

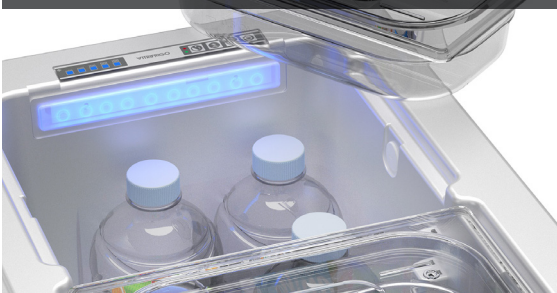

OUTBACK 46

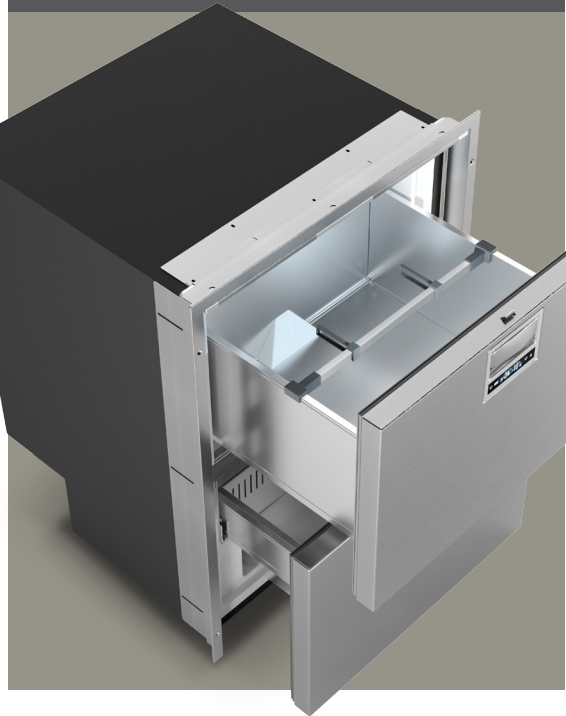

PORTABLES 76



3-WAYS 92



TECHNICAL DRAWINGS 100

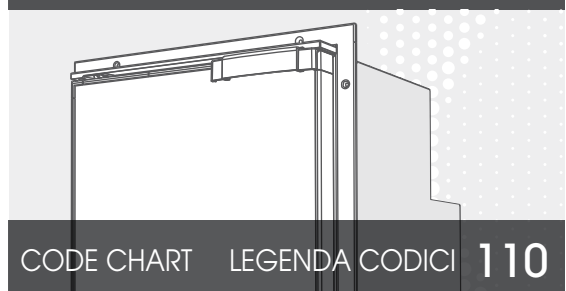

CODE CHART LEGENDA CODICI 110

CHROMELOCK is the new series of refrigerators and freezers. The door has been redesigned, both from an aesthetic and a functional point of view. With the same dimensions as the previous "Airlock" version, the new door is lighter, sturdier

and it can be customized quickly and easily using finishing panels with a thickness from 0.8 to 3.0 mm. Available in anti-fingerprint and anti-scratch matt black finish with soft touch effect, or in glossy gray laminate with pearl effect. The new CHROMELOCK handle, metallized and tested for over 150,000 opening and closing cycles, incorporates the "vent position" system for keeping it in a slightly open position when

not in use. The series is dedicated to any need and to any type of vehicle: fridge-freezer, fridge only, with door or drawer opening, also choosing whether to have an internal or remote refrigerating unit up to 1.5 m.

Chromelock also for the new and complete SLIM series: three models built and designed for camper van.

CHROMELOCK - BUILT-IN COOLING UNIT SERIES



	DP2600i CHR	DP150i CHR	C115i CHR	C90i CHR	C90DW CHR	C85i CHR	C62i CHR	C60i CHR	C51i CHR	
Total volume - Capacità totale (lt.)	230	150	115	90	90	85	62	60	51	
Freezer compartment - Vano freezer (lt.)	60	30	17,1	9,1	9,1	12,8	4,5	10,2	3,6	
Fridge+freezer - Frigo+freezer	•	•	•	•	•	•	•	•	•	
Fridge - Frigo			Optional			Optional		Optional		
Weight - Peso (kg.)	58,5	40,6	21,2	20,6	23,6	23,3	16,8	18,6	16	
Dimensions - Dimensioni (mm.)	 A = B = H =	631 602 1354	525 572 1103	525 560 766	470 557 622	470 559 622	485 469 791	450 559 530	470 457 622	380 524 532
Drawer opening - Apertura a cassetto					•					
Front opening - Apertura frontale	•	•	•	•		•	•	•	•	
Black finishing door - Porta colore nero	•	•	•	•	•	•	•	•	•	
Grey finishing door - Porta colore grey	•	•	•	•	•	•	•	•	•	
Compressor - Compressore	•	•	•	•	•	•	•	•	•	
Built-in cooling unit - Unità refrigerante interna	•	•	•	•	•	•	•	•	•	
Remote cooling unit - Unità refrigerante esterna										
Standard power supply - Alimentazione standard	12/24 Vdc									
Optional power supply - Alimentazione optional	12/24 Vdc 100-240 Vac 50/60Hz									
Nominal consumption - Consumo nominale (W)	65	65	45	45	45	45	40	40	40	
Digital thermostat - Termostato digitale										
Mechanical thermostat - Termostato meccanico	•	•	•	•	•	•	•	•	•	
Internal Led light - Luce interna a Led	•	•	•	•	•	•	•	•	•	
Reversible door - Porta reversibile	•	•	•	•	•	•	•	•	•	
Interchangeable panel - Pannello intercambiabile	•	•	•	•	•	•	•	•	•	
Vent position - Posizione di ventilazione	•	•	•	•	•	•	•	•	•	
Page nr. - Pagina n.	10	10	11	11	11	12	12	12	13	

CHROMELOCK è la nuova serie di frigoriferi e freezer in cui è stata ridisegnata l'anta, sia da un punto di vista estetico che da un punto di vista funzionale.

Con le stesse dimensioni della precedente versione "Airlock", la nuova porta è ancora più leggera e robusta ed è customizzabile in maniera semplice e veloce mediante pannelli di finitura con spessore da 0,8 a 3,0 mm. Disponibile in finitura nera opaca anti

impronta e antigraffio con effetto soft touch, oppure in laminato grigio lucido ad effetto perlato. La nuova maniglia CHROMELOCK, metallizzata e testata per oltre 150.000 cicli di apertura e chiusura, incorpora il sistema "vent position" per il mantenimento in posizione socchiusa in periodi di non utilizzo. La serie è dedicata a qualsiasi esigenza e a qualsiasi tipo di veicolo: frigo-freezer, solo frigo, con apertura ad anta o

a cassetto, potendo scegliere, inoltre, se utilizzare l'unità refrigerante in posizione interna o remotabile fino a 1,5 m..

Chromelock anche per la nuova e completa serie SLIM: tre modelli progettati e realizzati appositamente per il settore del camper-caravan.

CHROMELOCK - REMOTE COOLING UNIT SERIES

SLIM SERIES



C51DW CHR	C50i CHR	C39i CHR	C130L CHR	C95L CHR	C75L CHR	C75DW CHR	C42L CHR	C42DW CHR	C25L CHR	SLIM 250	SLIM 150	SLIM 90
51	50	39	130	95	75	75	42	42	25	250	140	82
3,6	3,6	3,6	17,1	12,8	10,2	10,2	3,6				16	10
•	•	•	•	•	•	•	•			•	•	•
	Optional	Optional	Optional	Optional	Optional	Optional	Optional	•	•			
19	15,7	16	25,2	22,3	18,6	21,6	15	18	12	59	37	19,3
380 526 532	396 397 636	390 397 547	525 565 767	485 471 792	470 460 622	470 462 622	380 384 532	380 386 532	422 322 442	595 650 1550	417 444 1513	417 489 925
•						•		•		•	•	
	•	•	•	•	•	•	•	•	•	•	•	•
•	•	•	•	•	•	•	•	•	•	•	•	•
•	•	•	•	•	•	•	•	•	•	•	•	•
•	•	•	•	•	•	•	•	•	•	•	•	•
•	•	•	•	•	•	•	•	•	•	•	•	•
			•	•	•	•	•	•	•	•	•	•
12/24 Vdc												
12/24 Vdc 100-240 Vac 50/60Hz												
40	40	31	45	45	40	40	31	31	34	75	70	39
										•	•	•
•	•	•	•	•	•	•	•	•	•			
•	•	•	•	•	•	•	•	•	•	•	•	•
•	•	•	•	•	•	•	•	•	•	•	•	•
•	•	•	•	•	•	•	•	•	•	•	•	•
•	•	•	•	•	•	•	•	•	•	•	•	•
13	13	13	14	14	14	15	15	15	15	22	23	23

Home comfort series. Dedicated to large campers and caravans, the combined fridge-freezers, both single-door and double-door, solve any need for large refrigerated spaces on-board. Ideal for anyone seeking the practicality, functionality and convenience of their home refrigerator.

Special installation series.

Designed to be installed in compact spaces, the two new D20A and D30A drawer refrigerators/freezers represent a revolutionary innovation in terms of both aesthetics and technology.

The series offers the additional advantage of not dispersing the cold even with numerous openings throughout the day.

Equipped with a practical removable container (BRK35 and C47), they occupy limited space,

while maintaining excellent usability.

Top loading series.

Built-in fridges/freezers with top opening (top loading) are designed to be specially housed in confined spaces.

They offer excellent performance even in extreme temperature conditions and, due to their low energy absorption, are particularly suitable for operation with solar energy.

HOME COMFORT **SPECIAL INSTALLATIONS**



	C270DP	C220DP	C190MP	C150MP	D20A	D30A
Total volume - Capacità totale (lt.)	271	220	200	125	20	30
Freezer compartment - Vano freezer (lt.)	78	44	19	15	ALL-IN ONE	ALL-IN ONE
Fridge+freezer - Frigo+freezer	•	•	•	•		
Dimensions - Dimensioni (mm.)	 A = 540 B = 500 H = 1790	A = 540 B = 500 H = 1445	A = 540 B = 555 H = 1210	A = 595 B = 545 H = 818	A = 440 B = 445 H = 250	A = 440 B = 585 H = 250
Weight - Peso (kg.)	56	43,5	39	29	15	17
Drawer opening - Apertura a cassetto					•	•
Front opening - Apertura frontale						
Top loading opening - Apertura a pozzetto						
Portable - Portatile						
Stainless steel finishing - Finitura in acciaio inox						
Standard finishing - Finitura standard	•	•	•	•	•	•
Black finishing door - Porta colore nero						
Grey finishing door - Porta colore grey						
White finishing panel - Pannello colore bianco	•	•	•	•	•	•
Compressor - Compressore	•	•	•	•	•	•
3-ways fridge - Frigo trivalente						
Built-in cooling unit - Unità refrigerante interna						
Remote cooling unit - Unità refrigerante esterna					•	•
Standard power supply - Alimentazione standard	12/24 Vdc					
Optional power supply - Alimentazione optional	12/24 Vdc 100-240 Vac 50/60Hz					
Nominal consumption - Consumo nominale (W)	61	56	56	58	43,5	43,5
Digital thermostat - Termostato digitale					•	•
Mechanical thermostat - Termostato meccanico	•	•	•	•		
Internal Led light - Luce interna a Led	•	•	•	•		
Reversible door - Porta reversibile	•	•	•	•		
Interchangeable panel - Pannello intercambiabile						
Page nr. - Pagina n.	28	29	29	29	35	35

Serie Home Comfort.

Dedicati ai camper e caravan di grandi dimensioni, i combinati frigo-freezer sia monoporta che a doppia porta risolvono qualsiasi esigenza di avere a bordo ampi spazi refrigerati. Per tutti coloro che non vogliono farsi mancare la praticità, la funzionalità e la comodità del proprio frigorifero domestico.

Serie installazioni speciali.











Una serie davvero speciale, pensata per

essere installata in spazi dalle dimensioni contenute. I due nuovi frigoriferi/freezer a cassetto D20A e D30A rappresentano una profonda innovazione di tipo sia estetico che tecnologico. Questa serie offre l'ulteriore vantaggio di non disperdere il freddo anche a fronte di numerose aperture nell'arco della giornata.

Dotati di pratico contenitore estraibile (BRK35 e C47), occupano spazi limitati, conservando al contempo un'ottima fruibilità.

Serie Top Loading.

I frigoriferi/freezer da incasso con apertura dall'alto (a pozzetto) sono progettati per essere alloggiati appositamente in spazi ristretti. Offrono eccellenti prestazioni anche in condizioni di temperature estreme e, per il loro basso assorbimento di energia, sono particolarmente indicati per il funzionamento con energia solare.

SPECIAL INSTALLATIONS				TOP LOADING					
									
BRK35P	BRK35PX	C47 CHR	KIT MAN	TL43	TL35RF	TL20RF	TL37L	TL37BT	TL40L
35	35	47	MAX 70	40	34	20	37	37	40
				ALL-IN ONE					
440 520 250	506 563 305	430 480 392	310 - 330 150 - 140 155 - 215	340 500 633	244 444 714	248 426 578	410 410 430	410 410 430	425 425 400
16	16,7	19	6	14,5	15	17	15	15	10
				•	•	•	•	•	•
	•								
•		•		•	•	•	•	•	•
•		•				•	•	•	•
		•					•	•	•
				•					
•	•	•	•	•	•	•	•	•	•
•	•	•		•	•	•	•	•	•
12/24 Vdc									
12/24 Vdc 100-240 Vac 50/60Hz						12/24 Vdc 100-240 Vac 50/60Hz			
31	31	31	26	45	28	28	45	45	31
				•	•				
•	•	•	•			•	•	•	•
•	•			•					
•	•					•			
•	•								
36	36	37	37	43	44	45	45	45	45

* For gas consumption, please see product page / Per il consumo di gas, consultare la pagina prodotto

All OCX2 series products are made of the best stainless steel quality and are equipped with the new Steelock system for opening-closing and ventilation in periods of non-use. These are reliable high-performance products, designed to face any journey or situation in conditions of absolute comfort, allowing you

to eat and drink just like being at home. Even better. The DRW series offers three all in one products: you can set the desired temperature (fridge or freezer) anytime, using a digital thermostat with the latest generation touch screen. Wide drawers, with cushioned sliding, in totally no-frost mode. The DW OCX2 series allows precise temperature regulation by means of a digital thermostat, offering drawer solutions for any refrigeration

need: fridge only - fridge-freezer and with internal icemaker. The Steel OCX2 series, equipped with a mechanical thermostat, offers the same performance and versatility as the Chromelock series, in stainless steel finishing.

The stainless steel range is completed by the new DW DRINKS series (with electronic thermostat) without freezer compartment, for beverage storage.

OUTBACK

DRW-ALL IN ONE

STAINLESS STEEL DRAWERS OCX2



	DRW 360A	DRW 180A	DRW 70A	DW360 OCX2	DW250 OCX2	C180 OCX2	DW210 OCX2	DW180 OCX2	DW100 OCX2	DW70 OCX2	DW35 OCX2
Total volume Capacità totale (lt.)	157+150	150	80	157+144	157+75	157	78+104	80+64	95	75	35
Freezer compartment Vano freezer (lt.)											
Fridge+freezer Frigo+freezer	ALL-IN ONE	ALL-IN ONE	ALL-IN ONE	•	•		•	•	•	•	•
Fridge Frigo					•	•	•	•	•	•	•
Weight Peso (kg.)	100	55	38	102*	67	41	61*	56*	32	33*	25
Internal icemaker Icemaker interno				•			•	•		•	
Dimensions Dimensioni (mm.)	 A = 682 B = 585 H = 1740	666 590 874	666 590 467	682 591 1697	682 584 1321	674 561 866	740 630 880	666 590 866	583 646 541	666 592 460	498 727 291
Drawer opening Apertura a cassetto	•	•	•	•	•		•	•	•	•	•
Front opening Apertura frontale	•			•	•	•					
Stainless steel finishing Finitura in acciaio inox	•	•	•	•	•	•	•	•	•	•	•
Compressor Compressore	•	•	•	•	•	•	•	•	•	•	•
Built-in cooling unit Unità refrigerante interna	•	•		•	•	•	•	•			
Remote cooling unit Unità refrigerante esterna			•						•	•	•
Standard power supply Alimentazione standard	12/24 Vdc										
Optional power supply Alimentazione optional	12/24 Vdc 100-240 Vac 50/60Hz										
Nominal consumption Consumo nominale (W)	48 + 96	96	96	45+61**	45+38**	45	45**	45**	40**	38**	31**
Digital thermostat Termostato digitale	•	•	•	•	•	•	•	•	•	•	•
Mechanical thermostat Termostato meccanico											
Internal Led light Luce interna a Led	•	•	•	•	•	•	•	•	•	•	•
Reversible door Porta reversibile	•			•	•	•					
Vent position Posizione di ventilazione	•	•	•	•	•	•	•	•	•	•	•
Page nr. - Pagina n.	52	53	53	58	58	59	59	60	60	61	61

* RFX version weight.
Peso in versione RFX.

** RFX version nominal consumption.
Consumo nominale in versione RFX.

For further versions (BTX, DTX, IM etc.) please see product page.
Per le altre versioni (DTX, BTX, IM ecc), consultare la pagina prodotto.

I prodotti della gamma OCX2 sono realizzati con acciaio Inox della migliore qualità e dotate del nuovo sistema. Steelock per apertura-chiusura e ventilazione nei periodi di non utilizzo. Si tratta di prodotti affidabili ad alte prestazioni, concepiti per affrontare qualsiasi viaggio o situazione in condizioni di assoluto comfort, consentendo di mangiare e bere proprio come a casa propria. Anzi, meglio.

La serie DRW offre tre prodotti all in one, in cui impostare a piacimento la temperatura desiderata (frigo o freezer), mediante un termostato digitale con touch screen di ultima generazione. Cassetti ampi, a scorrimento ammortizzato, in modalità totalmente no-frost. La serie DW OCX2, consente la regolazione precisa della temperatura mediante termostato digitale, offrendo soluzioni a cassetto per qualsiasi esigenza di

refrigerazione: solo frigo - frigo-freezer e con icemaker interno.

La serie Steel OCX2, dotata di termostato meccanico, offre le stesse prestazioni e la medesima versatilità della serie Chromelock, in finitura acciaio inox. Completa la gamma inox la nuova serie DW DRINKS (con termostato elettronico) senza cella freezer, per lo storage di bevande.

STAINLESS STEEL OCX2 BUILT-IN COOLING UNIT	STAINLESS STEEL OCX2 REMOTE COOLING UNIT	DW DRINKS
---	---	-----------



DP 2600iX OCX2	C115 iX OCX2	C90 iX OCX2	DW90 OCX2 RFX	C85 iX OCX2	C62 iX OCX2	DW62 OCX2 RFX	C60 iX OCX2	C51 iX OCX2	DW51 OCX2 RFX	C130 LX OCX2	C75 LX OCX2	DW75 OCX2 RFX	C42 LX OCX2	DW42 OCX2 RFX	DW51 OCX2 DRINKS	DW62 OCX2 DRINKS	DW90 OCX2 DRINKS
230	115	90	90	85	62	62	60	51	51	130	75	75	42	42	51	62	90
60	17,1	9,8	9,8	12,8	4,5	4,5	10,2	3,6	3,6	17,1	10,2	10,2	3,6				
•	•	•	•	•	•	•	•	•	•	•	•	•	•				
	Optional			Optional			Optional			Optional	Optional	Optional	Optional	•	•	•	•
63	32	27	30	29	22	27	24	20	23	33	25	28	18	22	23	27	30
631 602 1354	588 558 780	533 543 635	533 543 635	548 462 805	513 540 545	513 540 545	533 456 635	443 515 545	443 515 545	588 558 780	533 456 635	533 456 635	443 380 545	443 380 545	443 515 545	513 540 561	533 580 652
			•			•			•			•		•	•	•	•
•	•	•		•	•		•	•		•	•		•				
•	•	•	•	•	•	•	•	•	•	•	•	•	•	•	•	•	•
•	•	•	•	•	•	•	•	•	•	•	•	•	•	•	•	•	•
•	•	•	•	•	•	•	•	•	•						•	•	•
										•	•	•	•	•			
12/24 Vdc																	
12/24 Vdc 100-240 Vac 50/60Hz																	
65	45	45	45	45	40	40	40	40	40	45	40	40	31	31	50	50	50
															•	•	•
•	•	•	•	•	•	•	•	•	•	•	•	•	•	•			
•	•	•	•	•	•	•	•	•	•	•	•	•	•	•	•	•	•
•	•	•	•	•	•	•	•	•	•	•	•	•	•	•	•	•	•
•	•	•	•	•	•	•	•	•	•	•	•	•	•	•	•	•	•
66	66	67	67	67	68	68	69	69	69	70	70	71	71	71	75	75	75

VFREE portable series.

They offer excellent portability features, both in terms of reduced consumption and operational silence, and in terms of range and speed of reaching the desired temperature. Efficiency, versatility and compactness: with capacities ranging from 16 to 65 litres, they are a valid alternative to a traditional fridge/freezer.

VFREE PLUS portable series.

The VFREE PLUS series offers a complete range: from the small VFC15, 15 liters to be positioned under the armrest, up to the VFD115: 115 liters divided into two independent compartments with different temperatures. A very cool series, usable by a free app, but above all with incomparable autonomy: thanks to the high-performance lithium-ion battery and thanks also to the possibility of direct connection with the photovoltaic panel, there is the possibility of an external use without any limit.

3Ways Series.

The series of multi-function 3-ways refrigerators/freezers is designed to provide long periods of complete autonomy, powered either by gas (LPG) or electricity (230Vac) if connection to the mains is possible; otherwise, during travel, operation can be manually switched to 12Vdc, drawing energy from the motor alternator or from the photovoltaic system installed on the roof of your vehicle.

PORTABLES VFREE SERIES

PORTABLES VFREE PLUS SERIES



	VF65P	VF55P	VF45P	VF35P	VF16P	VFC15	VFT30	VFP40	VFP50
Total volume - Capacità totale (lt.)	65	55	45	35	16	15	30	40	50
Freezer compartment - Vano freezer (lt.)									
Fridge+freezer - Frigo+freezer	•	•	•	•	•	•	•	•	•
Dimensions - Dimensioni (mm.)	 A = B = H =	710 455 560	710 455 500	680 410 490	680 410 440	560 240 420	591 230 453	631 378 375	647 400 400 506
Weight - Peso (kg.)	23	22	20,5	19,5	8	9,3	12,8	14,7	15,7
Drawer opening - Apertura a cassetto									
Front opening - Apertura frontale									
Top loading opening - Apertura a pozzetto									
Portable - Portatile	•	•	•	•	•	•	•	•	•
Stainless steel finishing - Finitura in acciaio inox									
Standard finishing - Finitura standard									
Black finishing door - Porta colore nero									
Grey finishing door - Porta colore grey									
White finishing panel - Pannello colore bianco									
Compressor - Compressore	•	•	•	•	•	•	•	•	•
3-ways fridge - Frigo trivalente									
Built-in cooling unit - Unità refrigerante interna	•	•	•	•	•	•	•	•	•
Remote cooling unit - Unità refrigerante esterna									
Standard power supply - Alimentazione standard	STANDARD					STANDARD			
Optional power supply - Alimentazione optional	12/24 Vdc 100-240 Vac 50/60Hz					12/24 Vdc 100-240 Vac 50/60Hz			
Nominal consumption - Consumo nominale (W)	55	55	55	55	45	45	60	60	60
Digital thermostat - Termostato digitale	•	•	•	•	•	•	•	•	•
Mechanical thermostat - Termostato meccanico									
Internal Led light - Luce interna a Led	•	•	•	•	•	•	•	•	•
Reversible door - Porta reversibile									
Interchangeable panel - Pannello intercambiabile									
Page nr. - Pagina n.	82	82	83	83	83	88	88	89	89

Serie portatili VFREE.

I frigoriferi e freezer della serie VFREE by Vitrifrigo offrono eccellenti caratteristiche di portabilità, sia in consumi ridotti e di silenziosità operativa che in termini di range e velocità di raggiungimento della temperatura desiderata.

Efficienza, versatilità e compattezza: con capacità che vanno da 16 fino a 65 litri, rappresentano una valida alternativa ad un frigo/freezer di tipo tradizionale.

Serie portatili VFREE PLUS.

La serie VFREE PLUS offre un range davvero completo: dal VFC15, 15 litri da posizionarsi sotto il bracciolo, fino al VFD115:

con due scompartimenti indipendenti e temperature differenziate. Sono gestibili mediante app e dotati di un'autonomia senza precedenti: grazie alla batteria agli ioni di litio e al collegamento diretto col pannello fotovoltaico, si ha la possibilità di un utilizzo in esterni senza alcun limite di tempo.

Serie 3Ways - Trivalenti.

La serie dei frigoriferi/freezer trivalenti multifunzione è pensata per fornire lunghi periodi di completa autonomia, funzionando mediante alimentazione a gas (GPL) o elettricamente (230Vac) se si ha la possibilità di allaccio alla rete elettrica; diversamente, in viaggio il funzionamento può essere commutato manualmente a 12Vdc, prendendo l'energia o dall'alternatore del motore o dall'eventuale sistema fotovoltaico installato sul tetto dell'imbarcazione.

PORTABLES VFREE PLUS SERIES

3-WAYS

VFP60	VFT40	VFT50	VFT60	VFD75	VFD95	VFD115	VTR 5150 DG	VTR 5105 DG	VTR 5075 DG	VTR 5090 DG	VTR 5070 DG	VTR 5080 DG	VTR 5060 DG	VTR 5040 ES
60	40	50	60	75	95	115	150	92	72	84	61,5	74	51	40
							25,2	12,3	8,2	11	8,3	11	6,9	
•	•	•	•	•	•	•	•	•	•	•	•	•	•	•
647 400 571	711 460 441	711 460 506	711 460 571	937 535 465	1005 571 465	1005 571 523	525 546 1245	546 546 810	485 491 823	485 546 823	485 491 823	485 546 823	485 471 615	390 466 590
17,7	16,7	17,7	18,7	25,6	28	30,8	48,6	31,3	28	30	28	29,2	25,2	15
							•	•	•	•	•	•	•	•
•	•	•	•	•	•	•								
							•	•	•	•	•	•	•	•
							•	•	•	•	•	•	•	•
•	•	•	•	•	•	•	•	•	•	•	•	•	•	•
							•	•	•	•	•	•	•	•
STANDARD 12/24 Vdc 100-240 Vac 50/60Hz							12 Vdc / 230 Vac / Gas							
60	60	60	60	80	80	80	190/190*	110/130*	110/130*	110/130*	110/130*	110/130*	110/120*	80/80*
•	•	•	•	•	•	•								
•	•	•	•	•	•	•	•	•	•	•	•	•	•	•
							•	•	•	•	•	•	•	•
							•	•	•	•	•	•	•	•
89	90	90	90	91	91	91	98	98	98	98	99	99	99	99

* For gas consumption, please see product page / Per il consumo di gas, consultare la pagina prodotto

CHROMELOCK SERIES





The new complete range

LA NUOVA GAMMA COMPLETA

The Airlock series evolves in Chromelock series: the new complete range that covers every requirement in terms of space and capacity. Ergonomic, quiet, intuitive and safe, it is able to guarantee maximum on-board comfort.

La serie Airlock evolve in Chromelock: la nuova gamma completa che copre tutte le esigenze in termini di spazio e di capacità. Ergonomica, silenziosa, intuitiva e sicura, è in grado di garantire il massimo del comfort a bordo.

NEW



* Chromelock series availability is continuously updated: please contact us at sales@vitrefrigo.com

* La disponibilità della serie Chromelock è in continua evoluzione: contattateci per gli ultimi aggiornamenti a sales@vitrefrigo.com

Available models
Modelli disponibili

Total volume
Capacità totale

BUILT-IN COOLING UNIT / UNITÀ INTERNA

	LT.			
DP2600i CHR	230	●		
DP150i CHR	150	●		
C115i CHR	115	●	●	
C90i CHR	90	●		
C90DW CHR	90	●		●
C85i CHR	85	●	●	
C62i CHR	62	●		
C60i CHR	60	●	●	
C51i CHR	51	●		
C51DW CHR	51	●		●
C50i CHR	50	●	●	
C39i CHR	39	●	●	

REMOTE COOLING UNIT / UNITÀ ESTERNA

C130L CHR	130	●	●	
C95L CHR	95	●	●	
C75L CHR	75	●	●	
C75DW CHR	75	●	●	●
C42L CHR	42	●	●	
C42DW CHR	42		●	●
C25L CHR	25		●	



Fridge/Freezer
Frigo/Congelatore



Fridge
Frigo



Drawer
Cassetto

FRIDGES AND FREEZERS WITH BUILT-IN/REMOTE COOLING UNIT

FRIGORIFERI E FREEZER CON UNITÀ INTERNA/ESTERNA



INNOVATION BELONGS TO THOSE WITH A HISTORY.

Chromelock is the evolution of a high-profile design and production experience, able to combine technological innovation and design, with the functionality and quality of Made in Italy, in the search for a unique style that successfully combines essential elegance, quality value and unique personality.

L'INNOVAZIONE APPARTIENE A CHI HA UNA STORIA.

Chromelock è l'evoluzione di un'esperienza progettuale e produttiva di alto profilo, in grado di abbinare l'innovazione tecnologica e il design, con la funzionalità e la qualità del Made in Italy, nella ricerca di uno stile unico che sa unire eleganza essenziale, valore della qualità, personalità distintiva.



INCREASED DOOR THICKNESS
ANTA A SPESSORE MAGGIORATO



**ANTI-FINGERPRINT AND SCRATCH RESISTANT
FINISH WITH SOFT TOUCH EFFECT**
FINITURA ANTI IMPRONTA ED ANTIGRAFFIO
CON EFFETTO SOFT TOUCH



REPLACEABLE SEAL
GUARNIZIONE SOSTITUIBILE



METAL FINISH HANDLE
MANIGLIA CON FINITURA
METALLIZZATA



VENT POSITION SYSTEM
SISTEMA VENT POSITION



Form ever follows function

LA FORMA SEGUE SEMPRE LA FUNZIONE

THE NEW DOOR

- lighter with the same overall dimensions and totally built-in, with a smooth and elegant side frame, 42 mm thick.
- reversible and available in two colour variants: grey (Light) and black (Dark). The Light version has an elegant glossy grey laminated panel with a pearly effect, while in the Dark version the panel is matt black with anti-fingerprint and scratch resistant finish with soft touch effect.
- possibility to use finishing panels from 0.8 to 3.0 mm thick, guaranteeing simple and ultra-fast installation
- removable seal for its replacement and cleaning

THE NEW CHROMELOCK HANDLE

- elegant metal finish tested for over 150,000 opening and closing cycles
- carries out a positive and safe closing of the door
- integrated "vent position"

LA NUOVA PORTA

- più leggera a parità di ingombro e incasso totale, con un profilo laterale liscio ed elegante da 42 mm. di spessore
- reversibile e disponibile in due varianti cromatiche grigia (Light) e nera (Dark). La versione Light ha un elegante pannello laminato grigio lucido ad effetto perlato, mentre nella versione Dark il pannello è nero opaco con finitura anti impronta ed antigraffio con effetto soft touch.
- possibilità di utilizzare pannelli di finitura con spessori da 0,8 a 3,0 mm., per un'installazione semplice e ultrarapida
- guarnizione estraibile per la sua sostituzione e pulizia

LA NUOVA MANIGLIA CHROMELOCK

- elegante finitura metallizzata testata per oltre 150.000 cicli di apertura e chiusura
- effettua una chiusura positiva e sicura della porta
- "vent position" incorporata

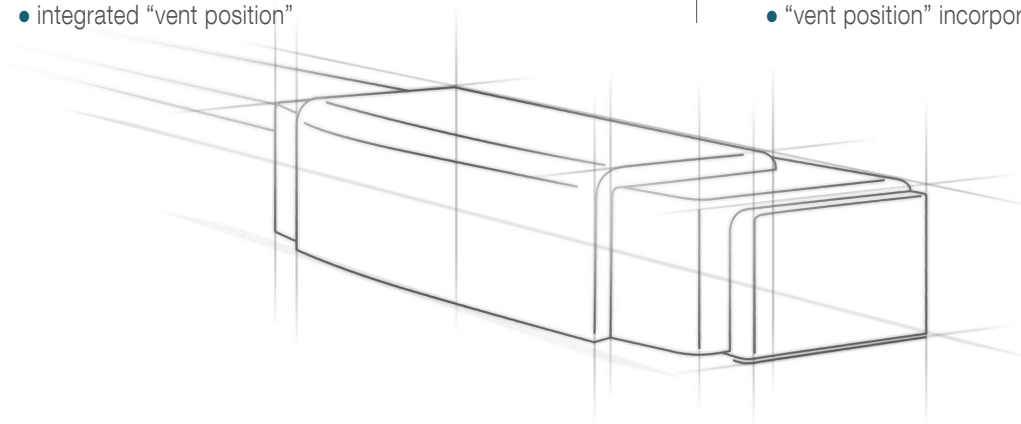



Chromelock: the smart locking system

CHROMELOCK: IL SISTEMA DI CHIUSURA INTELLIGENTE

The Chromelock system allows secure locking of the door even during intensive and extreme use of your boat.

Il sistema Chromelock permette il bloccaggio sicuro della porta anche durante l'uso intensivo ed estremo della vostra imbarcazione.

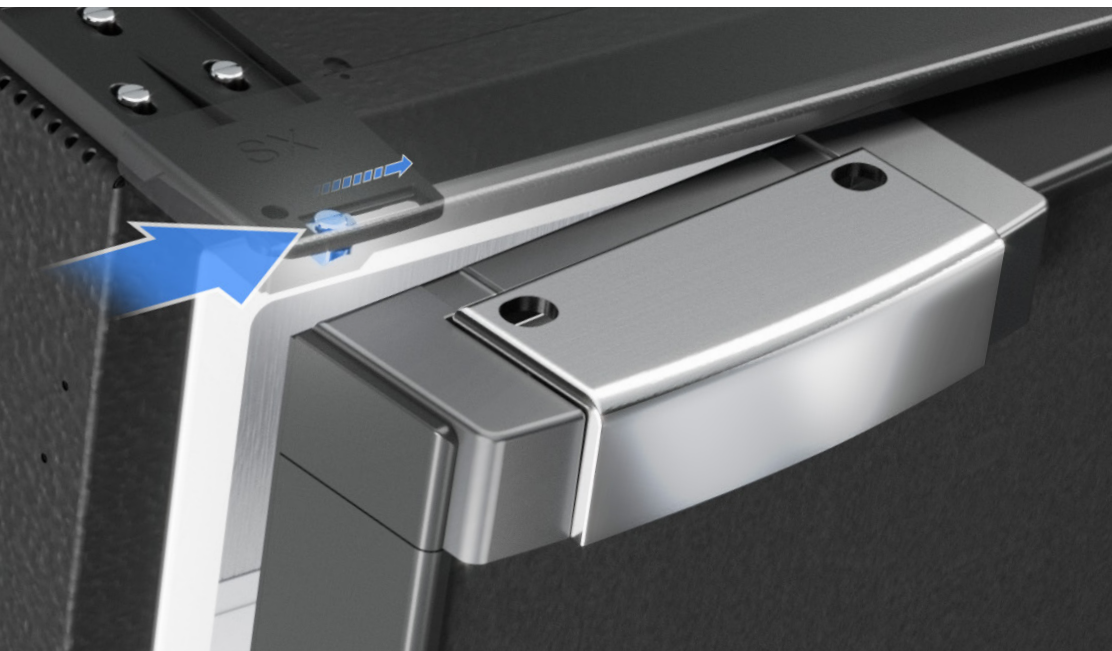

INTEGRATED VENT POSITION SISTEMA DI VENTILAZIONE INTEGRATO

A practical device incorporated in the Chromelock handle performs the "vent position" function, allowing the door to be held ajar, thus avoiding the formation of mould and odours during periods of non-use.

Un pratico dispositivo inglobato nella maniglia Chromelock realizza la funzione di "vent position", consentendo il mantenimento della porta in posizione socchiusa, evitando così la formazione di muffe e odori nei periodi di non utilizzo.

STANDARD



Double door colouring

DOPPIA COLORAZIONE DELLA PORTA

The series is available in light grey or black, to best respond to the customisation needs of your boat interiors.

La serie è disponibile in colorazione grigio perla o in colorazione nera, per una ottimale personalizzazione dell'ambiente interno della vostra imbarcazione.



BLACK

Black matte soft touch panel.
Pannello nero opaco effetto soft touch.



LIGHT GREY

Light grey glossy panel.
Pannello grigio perla effetto lucido.



Replaceable finishing panel

PANNELLO DI FINITURA SOSTITUIBILE



Finishing panels from 0.8 mm to 3.0 mm thick. Replace the panel quickly and easily using (1) interlocking flange, without the use of tools and screws.

Pannelli di finitura con spessori da 0,8 mm. a 3,0 mm. Sostituzione del pannello facile e veloce tramite (1) profilo ad incastro, senza l'uso di utensili e viti.



FRIDGE + FREEZER
FRIGORIFERO + FREEZER



FRIDGE
FRIGORIFERO



DRAWER
CASSETTO



OPTIONAL (Mounting flange / Profilo di fissaggio)



Door Inside
PORTA A FILO INTERNO



Door Outside
PORTA A FILO ESTERNO



The entire series can be installed by means of a mounting flange (optional), which by simply sliding it forward or back, allows both the totally built-in version (door inside) and the partially built-in version (door outside).

Tutta la serie ha la possibilità di essere installata mediante un profilo di fissaggio (optional), che permette tramite il suo semplice scorrimento in avanti o indietro sia la versione a incasso totale (door inside) che quella a incasso parziale (door outside).



Remotable cooling unit
UNITÀ DI REFRIGERAZIONE REMOTABILE

The remotable external cooling unit offers added available volume inside the refrigerator. In addition, it expands the installation possibilities in terms of functionality, efficiency and soundproofing.

L'unità di refrigerazione esterna remotabile permette di avere maggior volume a disposizione all'interno del frigorifero. Inoltre, espande le possibilità di installazione, sia in termini di funzionalità che di efficienza e insonorizzazione.

Up to 1,5
FINO A mt.

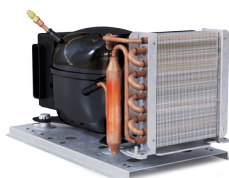

Dual electronic control
CENTRALINA BIVALENTE

12/24 Vdc 100/240 Vac
50/60 Hz





DP2600i CHR

Total volume Capacità totale	230 lt.
Freezer compartment Vano freezer	60 lt.
Net weight Peso netto	58,5 kg.
Power supply and nominal consumption Alimentazione e consumo nominale	12/24 Vdc 65 W

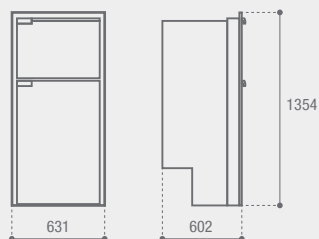





OPTIONAL
 12/24Vdc
 100-240Vac



DP150i CHR

Total volume Capacità totale	150 lt.
Freezer compartment Vano freezer	30 lt.
Net weight Peso netto	40,6 kg.
Power supply and nominal consumption Alimentazione e consumo nominale	12/24 Vdc 65 W

Dimension without fitting frame (optional)
Dimensioni senza profilo di fissaggio (optional)

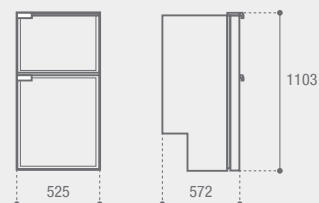





OPTIONAL
 12/24Vdc
 100-240Vac



LED

OPTIONAL
FridgeFridge
FreezerOPTIONAL
12/24Vdc
100-240Vac

C115i CHR

Total volume Capacità totale	115 lt.
Freezer compartment Vano freezer	17,1 lt.
Net weight Peso netto	21,2 kg.
Power supply and nominal consumption Alimentazione e consumo nominale	12/24 Vdc 45 W

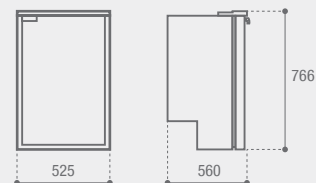

LED

Fridge
FreezerOPTIONAL
12/24Vdc
100-240Vac

C90i CHR

Total volume Capacità totale	90 LT.
Freezer compartment Vano freezer	9,1 LT.
Net weight Peso netto	20,6 kg.
Power supply and nominal consumption Alimentazione e consumo nominale	12/24 Vdc 45 W

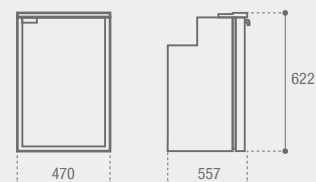

LED

Fridge
FreezerOPTIONAL
12/24Vdc
100-240VacH max
280 mm.

C90DW CHR

Total volume Capacità totale	90 lt.
Freezer compartment Vano freezer	9,1 lt.
Net weight Peso netto	23,6 kg.
Power supply and nominal consumption Alimentazione e consumo nominale	12/24 Vdc 45 W



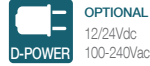

C85i CHR

Total volume Capacità totale	85 lt.
Freezer compartment Vano freezer	12,8 lt.
Net weight Peso netto	23,3 kg.
Power supply and nominal consumption Alimentazione e consumo nominale	12/24 Vdc 45 W

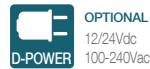
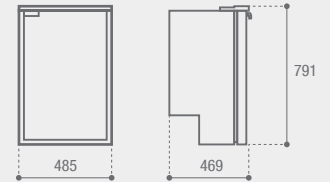

C62i CHR

Total volume Capacità totale	62 lt.
Freezer compartment Vano freezer	4,5 lt.
Net weight Peso netto	16,8 kg.
Power supply and nominal consumption Alimentazione e consumo nominale	12/24 Vdc 40 W

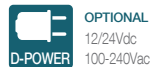
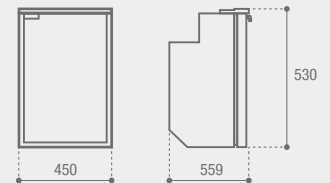

C60i CHR

Total volume Capacità totale	60 lt.
Freezer compartment Vano freezer	10,2 lt.
Net weight Peso netto	18,6kg.
Power supply and nominal consumption Alimentazione e consumo nominale	12/24 Vdc 40 W

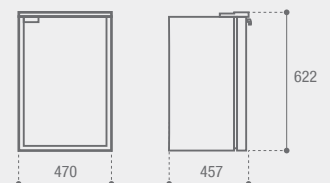



Fridge
Freezer

OPTIONAL
12/24Vdc
100-240Vac

C51i CHR

Total volume Capacità totale	51 lt.
Freezer compartment Vano freezer	3,6 lt.
Net weight Peso netto	16 kg.
Power supply and nominal consumption Alimentazione e consumo nominale	12/24 Vdc 40 W

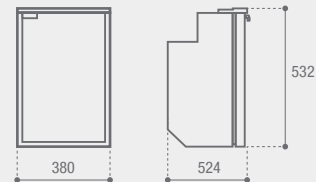

H max
250 mm.



Fridge
Freezer

OPTIONAL
12/24Vdc
100-240Vac

C51DW CHR

Total volume Capacità totale	51 lt.
Freezer compartment Vano freezer	3,6 lt.
Net weight Peso netto	19 kg.
Power supply and nominal consumption Alimentazione e consumo nominale	12/24 Vdc 40 W

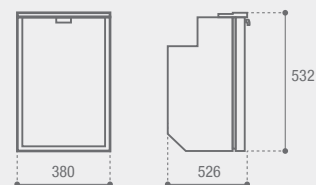

OPTIONAL
Fridge

Fridge
Freezer

OPTIONAL
12/24Vdc
100-240Vac

C50i CHR

Total volume Capacità totale	51 lt.
Freezer compartment Vano freezer	3,6 lt.
Net weight Peso netto	15,7 kg.
Power supply and nominal consumption Alimentazione e consumo nominale	12/24 Vdc 40 W

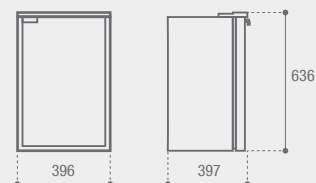

OPTIONAL
Fridge

Fridge
Freezer

OPTIONAL
12/24Vdc
100-240Vac

C39i CHR

Total volume Capacità totale	39 lt.
Freezer compartment Vano freezer	3,6 lt.
Net weight Peso netto	16 kg.
Power supply and nominal consumption Alimentazione e consumo nominale	12/24 Vdc 31 W

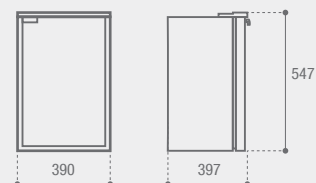



C130L CHR

Total volume Capacità totale	130 lt.
Freezer compartment Vano freezer	17,1 lt.
Net weight Peso netto	25,2 kg.
Power supply and nominal consumption Alimentazione e consumo nominale	12/24 Vdc 45 W

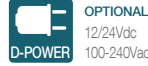
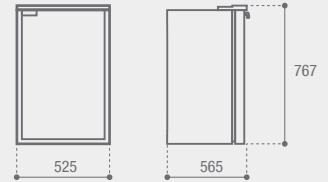

C95L CHR

Total volume Capacità totale	95 lt.
Freezer compartment Vano freezer	12,8 lt.
Net weight Peso netto	22,3 kg.
Power supply and nominal consumption Alimentazione e consumo nominale	12/24 Vdc 45 W

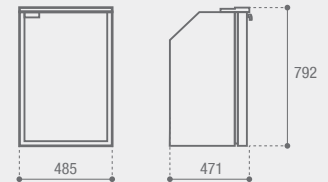

C75L CHR

Total volume Capacità totale	75 lt.
Freezer compartment Vano freezer	10,2 lt.
Net weight Peso netto	18,6 kg.
Power supply and nominal consumption Alimentazione e consumo nominale	12/24 Vdc 40 W

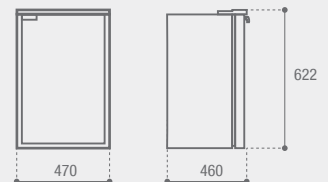



 H max
330 mm.



C75DW CHR

Total volume Capacità totale	75 lt.
Freezer compartment Vano freezer	10,2 lt.
Net weight Peso netto	21,6 kg.
Power supply and nominal consumption Alimentazione e consumo nominale	12/24 Vdc 40 W

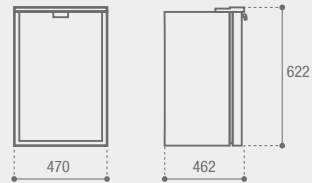

C42L CHR

Total volume Capacità totale	42 lt.
Freezer compartment Vano freezer	3,6 lt.
Net weight Peso netto	15 kg.
Power supply and nominal consumption Alimentazione e consumo nominale	12/24 Vdc 31 W

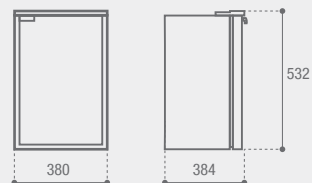

 H max
420 mm.



C42DW CHR

Total volume Capacità totale	42 lt.
Net weight Peso netto	18 kg.
Power supply and nominal consumption Alimentazione e consumo nominale	12/24 Vdc 31 W

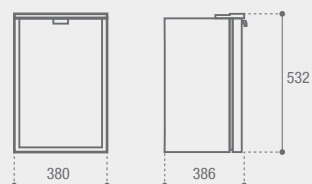

C25L CHR

Total volume Capacità totale	25 lt.
Net weight Peso netto	12 kg.
Power supply and nominal consumption Alimentazione e consumo nominale	12/24 Vdc 34 W

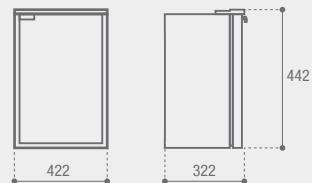

SLIM SERIES





AS SLIM AS EVER

Slim, capacious and high performing.

Three models suitable for use in any indoor space, to provide perfect storage of food and drinks even on the hottest days.

The two models SLIM90 and SLIM150, with remote cooling unit, are configured to operate in refrigeration mode, at the same time having a generous freezer compartment, while the new SLIM250, with internal cooling unit, model offers a large refrigerator in the upper part and the possibility of choosing refrigerator or freezer in the lower part.

Snelli, capienti e decisamente performanti.

Tre modelli adatti ad essere impiegati in qualsiasi spazio interno, per fornire la perfetta conservazione di cibi e bevande anche nelle giornate più calde.

I due modelli SLIM90 e SLIM150, con unità refrigerante esterna e remotabile, sono configurati per funzionare in modalità frigorifera, disponendo al contempo di una generosa cella freezer, mentre il nuovo modello SLIM250, con unità refrigerante interna, offre un ampio frigorifero nella parte superiore e la possibilità di scegliere frigorifero o freezer nella parte inferiore.

Available models Modelli disponibili	Total volume Capacità totale
EXTERNAL COOLING UNIT UNITÀ ESTERNA	LT.
SLIM 90	82
SLIM 150	140
SLIM 250	250

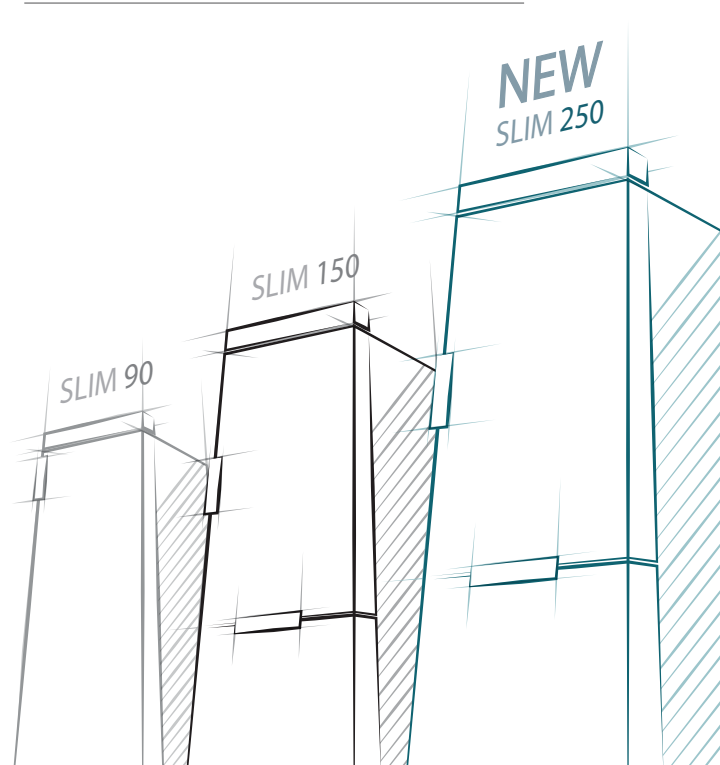

SLIM SERIES

BUILT AND DESIGNED FOR CAMPERVAN

CLIMATE CLASS: T



NIGHT MODE

VERY LOW NOISE AND HIGH ENERGY SAVINGS

SILENZIOSITÀ ASSOLUTA E RISPARMIO ENERGETICO



TURBO MODE

FAST CHILL SET POINT TEMPERATURE

RAPIDO RAGGIUNGIMENTO DELLA TEMPERATURA

SLIM250



NO FROST

VENTILATED COOLING SYSTEM

SISTEMA DI VENTILAZIONE INTERNA

SLIM90/150



3-STAR FREEZER

FOR FROZEN FOOD AT -18°C

PER IL CORRETTO CONGELAMENTO A -18°C



SLIM 250

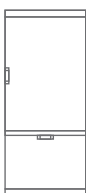

190 LT.
VENTILATED FRIDGE
FRIGORIFERO VENTILATO

60 LT.
DRAWER FRIDGE/FREEZER
FRIGORIFERO/CONGELATORE A CASSETTO



INTERNAL COOLING UNIT
UNITÀ REFRIGERANTE INTERNA



SLIM 150



90 LT.
FRIDGE WITH 3-STAR
FREEZER COMPARTMENT
FRIGORIFERO CON
CELLA FREEZER A 3 STELLE

60 LT.
DRAWER FRIDGE
FRIGORIFERO A CASSETTO



REMOVABLE COOLING UNIT
UNITÀ REFRIGERANTE REMOTABILE



SLIM 90



82 LT.
FRIDGE WITH 3-STAR
FREEZER COMPARTMENT
FRIGORIFERO CON
CELLA FREEZER A 3 STELLE



REMOVABLE COOLING UNIT
UNITÀ REFRIGERANTE REMOTABILE



A complete series to offer higher performance

UNA SERIE COMPLETA PER OFFRIRE PRESTAZIONI ANCORA PIÙ ELEVATE

THE NEW DOOR

With the new anti-fingerprint and scratch-resistant finish with soft touch effect panel and the new handle of the Chromelock series, the new door is lighter, in the face of greater thickness and strength.

Now it's possible to use finishing panels from 0,8 to 3,0 mm. thick, for a simple and ultra-fast "screw-free" installation and remove the seal for replacement and cleaning.

THE NEW DRAWER

Completely redesigned to be lighter, while optimizing the containment and division of the internal space, thanks to the new repositionable partition.

THE NEW PERFORMANCES

Equipped with a latest generation compressor, the SLIM Series reaches the desired temperature in a very short time, ensuring continuous operation at the top of the category.

LA NUOVA ANTA

Con il nuovo pannello con finitura anti impronta ed antigraffio con effetto soft touch e la nuova maniglia della serie Chromelock, la nuova anta è più leggera, a fronte di maggior spessore e robustezza.

È possibile la personalizzazione mediante pannelli di finitura con spessori da 0,8 sino a 3 mm., installabili in maniera semplice e veloce; è inoltre possibile rimuovere la guarnizione per la sua pulizia o sostituzione.

IL NUOVO CASSETTO

Completamente ridisegnato per risultare più leggero, ottimizzando al contempo il contenimento e la suddivisione dello spazio interno, grazie al nuovo divisorio riposizionabile.

LE NUOVE PERFORMANCES

Equipaggiata con un compressore di ultima generazione, la Serie SLIM raggiunge la temperatura desiderata in tempi rapidissimi, garantendo un funzionamento continuo ai massimi vertici della categoria.

SLIM SERIES

BUILT AND DESIGNED FOR CAMPERVAN



SLIM 250



UP TO 30%
ENERGY CONSUMPTION
SAVING

ALL IN ONE

2 INDEPENDENT COOLING
COMPARTMENTS
YOU DECIDE.
USE BOTH OR JUST ONE

2 VANI REFRIGERATI
INDIPENDENTI.
DECIDI SE USARNE UNO
OPPURE ENTRAMBI



**CI BUS
READY**

**2 x
10lt.**

CRISPER BINS
CONTENITORI PORTAFRUTTA

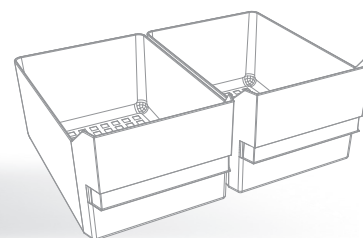



Multi-function thermostat with integrated white led lighting

TERMOSTATO MULTIFUNZIONE CON ILLUMINAZIONE A LED BIANCA INTEGRATA

THE NEW CONTROL PANEL

Integrated advanced control panel on the top of the fridge, with two high brightness white Led lights.

IL NUOVO PANNELLO COMANDI

Pannello di controllo avanzato integrato nella parte superiore del frigorifero, dotato di due Led bianchi ad alta luminosità.



VENT POSITION SYSTEM
SISTEMA VENT POSITION

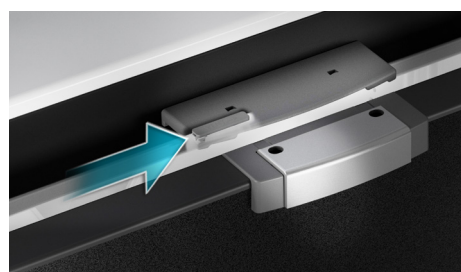

The device integrated in the Steelock handle offers the "vent position" function, allowing the door to be held ajar and thus avoiding the formation of mould and odours during periods of non-use.

Il dispositivo integrato nella maniglia Steelock offre la funzione di "vent position", consentendo di tenere la porta socchiusa, evitando la formazione di muffe e odori nei periodi di non utilizzo.

Finishing panel in two colours: dark and light

PANNELLO DI FINITURA IN DUE COLORAZIONI: DARK E LIGHT

The new door is reversible and available in two colour variants: **Light Grey** and **Black**. The Light Grey version has an elegant glossy grey laminated panel with a pearly effect, while in the Black version the panel is matt black with anti-fingerprint and scratch resistant finish with soft touch effect.

La nuova porta è reversibile e disponibile in due varianti cromatiche: grigia (**Light Grey**) e nera (**Black**). La versione Light Grey ha un elegante pannello laminato grigio lucido ad effetto perlato, mentre nella versione Black il pannello è nero opaco con finitura anti impronta ed antigraffio con effetto soft touch.



SLIM250 CHR

NEW



R600a

NATURAL GAS COMPRESSOR | COMPRESSORE A GAS NATURALE



LED



INTERNAL COOLING UNIT
UNITÀ REFRIGERANTE INTERNA



H max
350 mm.

Total volume Capacità totale	250 lt.
Net weight Peso netto	59 kg.
Power supply and nominal consumption Alimentazione e consumo nominale	12/24 Vdc 75 W

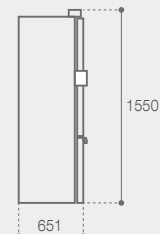
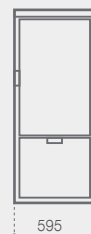



R290
NATURAL GAS COMPRESSOR | COMPRESSORE A GAS NATURALE



SLIM150 CHR

Total volume Capacità totale	140 lt.
Freezer compartment Vano freezer	16 lt.
Net weight Peso netto	37 kg.
Power supply and nominal consumption Alimentazione e consumo nominale	12/24 Vdc 70 W

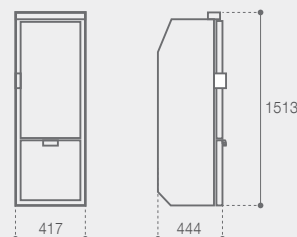

H max
365 mm.

Remotable cooling unit UNITÀ DI REFRIGERAZIONE REMOTABILE

The remotable external cooling unit offers added available volume inside the refrigerator. In addition, it expands the installation possibilities in terms of functionality, efficiency and soundproofing.

Up to
FINO A 1,5
mt.

L'unità di refrigerazione esterna remotabile permette di avere maggior volume a disposizione all'interno del frigorifero. Inoltre, espande le possibilità di installazione, sia in termini di funzionalità che di efficienza e insonorizzazione.

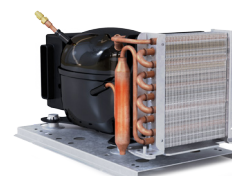

R600a
NATURAL GAS COMPRESSOR | COMPRESSORE A GAS NATURALE



SLIM90 CHR

NEW

Total volume Capacità totale	82 lt.
Freezer compartment Vano freezer	10 lt.
Net weight Peso netto	19,3 kg.
Power supply and nominal consumption Alimentazione e consumo nominale	12/24 Vdc 39 W

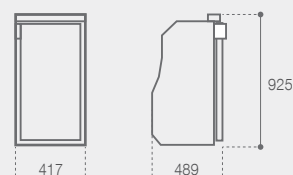

HOME COMFORT





Feel at home

SENTIRSI A CASA

Dedicated to large campers and caravans, the combined fridge-freezers, both single-door and double-door, solve any need for large refrigerated spaces on-board. Ideal for anyone seeking the practicality, functionality and convenience of their home refrigerator.

Dedicati ai camper e caravan di grandi dimensioni, i combinati frigo-freezer sia monoporta che a doppia porta risolvono qualsiasi esigenza di avere a bordo ampi spazi refrigerati. Per tutti coloro che non vogliono farsi mancare la praticità, la funzionalità e la comodità del proprio frigorifero domestico.

Available models Modelli disponibili

Total volume Capacità totale

	LT.
C270DP	271
C220DP	220
C190MP	190
C150MP	125



HOME
COMFORT



Perfect internal sanitisation

PERFETTA IGIENIZZAZIONE INTERNA

The interior walls of the refrigerators are treated by a natural system to inhibit the onset of mould and bacteria and to protect the integrity of food, while the innovative gaskets ensure the protection of even the outermost areas of the refrigerator.

Le pareti interne dei frigoriferi sono trattate mediante un sistema naturale per inibire l'insorgere di muffe e batteri e proteggere l'integrità degli alimenti, mentre le innovative guarnizioni assicurano la protezione anche delle zone più esterne del frigorifero.



High potential lighting

ILLUMINAZIONE AD ALTO POTENZIALE

The internal lighting system includes the standard installation of a very bright top light making sure all parts of the refrigerator are properly lit.

Il sistema di illuminazione interna prevede l'installazione di serie di una plafoniera ad alta luminosità che garantisce il raggiungimento della luce in qualsiasi punto del frigorifero.





Fresh and crisp fruit and vegetables

FRUTTA E VERDURA FRESCHE E CROCCANTI

The perfect control of humidity levels, together with minimised temperature variations inside the fruit and vegetable drawer, mean that stored food is kept fresh and crisp.

Il perfetto controllo dei livelli di umidità, unitamente a variazioni di temperatura minimizzate all'interno del cassetto frutta e verdura, fanno sì che si riescano a conservare alimenti sempre freschi e croccanti.

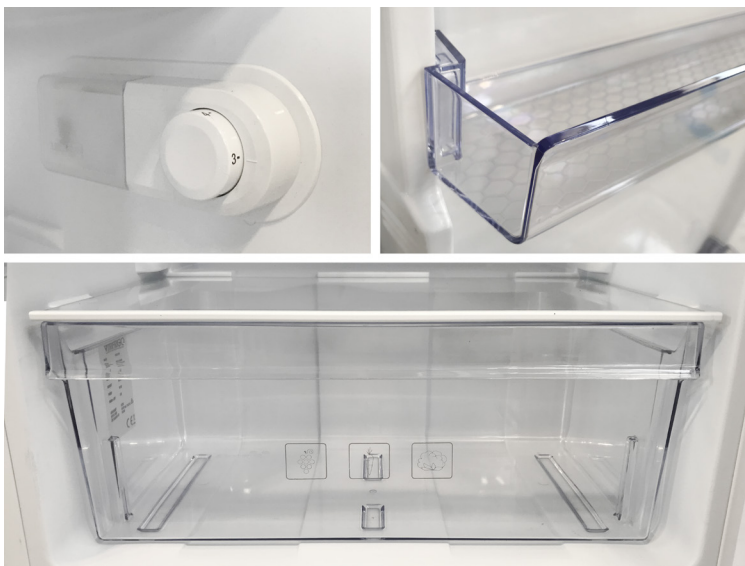

OPTIONAL Dual electronic control CENTRALINA BIVALENTE

12/24 Vdc
100-240 Vac
50/60 Hz



C270DP

Total volume Capacità totale	271 lt.
Freezer compartment Vano freezer	78 lt.
Net weight Peso netto	56 kg.
Power supply and nominal consumption Alimentazione e consumo nominale	12/24 Vdc 61 W

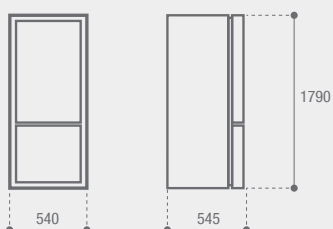

LED



OPTIONAL
12/24Vdc
100-240Vac





LED



OPTIONAL
12/24Vdc
100-240Vac

C220DP

Total volume Capacità totale	220 lt.
Freezer compartment Vano freezer	44 lt.
Net weight Peso netto	43,5 kg.
Power supply and nominal consumption Alimentazione e consumo nominale	12/24 Vdc 56 W

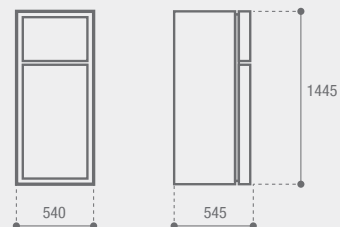

LED



OPTIONAL
12/24Vdc
100-240Vac

C190MP

Total volume Capacità totale	200 lt.
Freezer compartment Vano freezer	19 lt.
Net weight Peso netto	39 kg.
Power supply and nominal consumption Alimentazione e consumo nominale	12/24 Vdc 56 W

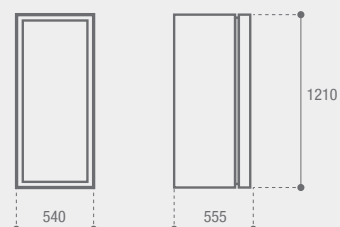

LED



OPTIONAL
12/24Vdc
100-240Vac

C150MP

Total volume Capacità totale	125 lt.
Freezer compartment Vano freezer	15 lt.
Net weight Peso netto	29 kg.
Power supply and nominal consumption Alimentazione e consumo nominale	12/24 Vdc 58 W

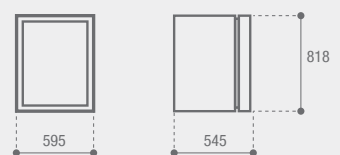

SPECIAL INSTALLATIONS





Special...from any point of view

SPECIALI... SOTTO OGNI PUNTO DI VISTA.

A very special series, designed to be installed in compact spaces. The two new D20A and D30A drawer refrigerators/freezers represent a revolutionary innovation in terms of both aesthetics and technology.

The drawer refrigerators for special installations offer the additional advantage of not dispersing the cold even with numerous openings throughout the day.

Equipped with a practical removable container (BRK35 and C47), they occupy limited space, while maintaining excellent usability.

Una serie davvero speciale, pensata per essere installata in spazi dalle dimensioni contenute.

I due nuovi frigoriferi/freezer a cassetto D20A e D30A rappresentano una profonda innovazione di tipo sia estetico che tecnologico.

I frigoriferi per le installazioni speciali a cassetto offrono l'ulteriore vantaggio di non disperdere il freddo anche a fronte di numerose aperture nell'arco della giornata.

Dotati di pratico contenitore estraibile (BRK35 e C47), occupano spazi limitati, conservando al contempo un'ottima fruibilità.

Available models Modelli disponibili

Total volume Capacità totale

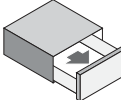
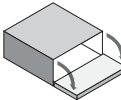
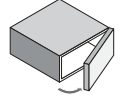
	LT.	
D20 A	20	
D30 A	30	
BRK35P	35	
BRK35PX	35	
C47 CHR	47	
KIT MAN	70 max	

SPECIAL INSTALLATIONS

COMPACT DRAWER
REFRIGERATORS AND FREEZERS

INSTALLAZIONI SPECIALI

FRIGORIFERI E FREEZER
COMPATTI A CASSETTO

NEW

YOU DECIDE.
ANY TEMPERATURE
ANY TIME.



R600a

NATURAL GAS COMPRESSOR | COMPRESSORE
A GAS NATURALE

