

OVERTRUCK



VITRIFRIGO

MADE IN ITALY





FREEZE YOUR MOMENTS

RENDI UNICO OGNI MOMENTO SPECIALE

INNOVAZIONE, DESIGN E **ECOSOSTENIBILITÀ**:
è la Mission di Vitrifrigo e fa parte di una più ampia
strategia aziendale volta al profondo rispetto
degli obblighi ambientali.

Abbiamo dato vita ad una vera e propria politica
per continuare il nostro impegno a operare come
società responsabile, coinvolgendo direttamente
o indirettamente tutti gli aspetti delle attività
aziendali: progettazione, ingegneria, produzione,
manutenzione dei prodotti o distribuzione delle
loro parti.

In linea con questa politica, Vitrifrigo ha investito
risorse multiple per rinnovare le serie dei prodotti
integrando soluzioni a basso GWP e Gas Naturale.

MAKE EVERY SPECIAL MOMENT UNIQUE

INNOVATION, DESIGN AND **ECO-SUSTAINABILITY**:
This is the fundamental core of Vitrifrigo and is part
of a broader corporate strategy aimed at
respecting environmental obligations.

We have developed a policy to continue our
commitment to operate as a responsible
company. This covers every aspect of the
company's activities, whether directly or indirectly
involved in the design, engineering,
manufacturing, maintenance of our products, or
distribution of their parts.

In line with this policy, Vitrifrigo has invested
multiple resources to renew the ranges of products
with low GWP and Natural Gas solutions.

OVERTRUCK

VITRIFRIGO

COOL AND BEYOND

<p>STRATOS 08</p> 	<p>ROADWIND 3000 14</p> 
--	---

<p>CHROMELOCK SERIES 16</p> 

<p>PORTABLES 26</p> 
--

<p>SPECIAL INSTALLATIONS 38</p> 

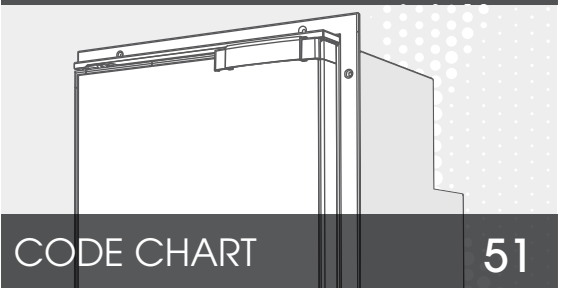
<p>TECHNICAL DRAWINGS 48</p> 
<p>CODE CHART 51</p>

CHROMELOCK is the new series of refrigerators and freezers. The door has been redesigned, both from an aesthetic and a functional point of view. With the same dimensions as the previous "Airlock" version, the new door is lighter, sturdier and it can be customized quickly and easily using finishing panels with a thickness from 0.8 to 3.0 mm. Available in anti-fingerprint and anti-scratch matt black finish with soft touch effect, or in glossy gray

laminated with pearl effect. The new CHROMELOCK handle, metallized and tested for over 150,000 opening and closing cycles, incorporates the "vent position" system for keeping it in a slightly open position when not in use. PORTABLE SERIES. They offer excellent portability features, both in terms of reduced consumption and operational silence, and in terms of range and speed of reaching the desired temperature. Efficiency, versatility and compactness: with capacities ranging from 16 to 65 litres, they are a valid alternative to a traditional fridge/freezer. SPECIAL INSTALLATION SERIES. Designed to be

installed in compact spaces, the two new D20A and D30A drawer refrigerators/freezers represent a revolutionary innovation in terms of both aesthetics and technology. The series offers the additional advantage of not dispersing the cold even with numerous openings throughout the day. Equipped with a practical removable container (BRK35 and C47), they occupy limited space, while maintaining excellent usability. M25, V26, V31, S44 fridges are dedicated to specific truck brands (respectively: Mercedes, Volvo, Volvo Scania).

CHROMELOCK



	C62i CHR	C60i CHR	C51i CHR	C51DW CHR	C50i CHR	C39i CHR	C42L CHR	C42DW CHR	C25L CHR		
Total volume - Capacità totale (lt.)	62	60	51	51	50	39	42	42	25		
Freezer compartment - Vano freezer (lt.)	4,5	10,2	3,6	3,6	3,6	3,6	3,6				
Fridge+freezer - Frigo+freezer	•	•	•	•	•	•	•				
Only fridge - Solo frigo		Optional			Optional	Optional	Optional	•	•		
Weight - Peso (kg.)	16,8	18,6	16	19	15,7	16	15	18	12		
Dimensions - Dimensioni (mm.)		A = B = H =	450 559 530	470 457 622	380 524 532	380 526 532	396 397 636	390 397 547	380 384 532	380 386 532	422 322 442
Drawer opening - Apertura a cassetto				•				•			
Front opening - Apertura frontale	•	•	•		•	•	•		•		
Top loading opening - Apertura a pozzetto											
Portable - Portatile											
Standard finishing - Finitura standard											
Black finishing door - Porta colore nero	•	•	•	•	•	•	•	•	•		
Grey finishing door - Porta colore grigio	•	•	•	•	•	•	•	•	•		
White finishing door - Porta colore bianco											
Compressor - Compressore	•	•	•	•	•	•	•	•	•		
Built-in cooling unit - Unità refrigerante interna	•	•	•	•	•	•					
Remote cooling unit - Unità refrigerante esterna							•	•	•		
Standard power supply - Alimentazione standard (Vdc)	12/24	12/24	12/24	12/24	12/24	12/24	12/24	12/24	12/24		
Optional power supply - Alimentazione optional (Vac)	100/240	100/240	100/240	100/240	100/240	100/240	100/240	100/240	100/240		
Nominal consumption - Consumo nominale (W)	40	40	40	40	40	31	31	31	34		
Digital thermostat - Termostato digitale											
Led thermostat - Termostato a Led											
Mechanical thermostat - Termostato meccanico	•	•	•	•	•	•	•	•	•		
Internal Led light - Luce interna a Led	•	•	•	•	•	•	•	•	•		
Reversible door - Porta reversibile	•	•	•	•	•	•	•	•	•		
Interchangeable panel - Pannello intercambiabile	•	•	•	•	•	•	•	•	•		
Vent position - Posizione di ventilazione	•	•	•	•	•	•	•	•	•		
Page nr. - Pagina n.	22	22	23	23	24	24	25	25	25		

CHROMELOCK è la nuova serie di frigoriferi e freezer in cui è stata ridisegnata l'anta, sia da un punto di vista estetico che da un punto di vista funzionale. Con le stesse dimensioni della precedente versione "Airlock", la nuova porta è ancora più leggera e robusta ed è customizzabile in maniera semplice e veloce mediante pannelli di finitura con spessore da 0,8 a 3,0 mm. Disponibile in finitura nera opaca anti impronta e antigraffio con effetto soft touch, oppure in laminato grigio lucido ad effetto perlato. La nuova maniglia CHROMELOCK, metallizzata e testata per oltre 150.000 cicli di apertura e chiusura, incorpora

il sistema "vent position" per il mantenimento in posizione socchiusa in periodi di non utilizzo. SERIE PORTATILI. I frigoriferi e freezer portatili offrono eccellenti caratteristiche di portabilità, sia in consumi ridotti e di silenziosità operativa che in termini di range e velocità di raggiungimento della temperatura desiderata. Efficienza, versatilità e compattezza: con capacità che vanno da 16 fino a 65 litri, rappresentano una valida alternativa ad un frigo/freezer di tipo tradizionale. SERIE INSTALLAZIONI SPECIALI. Una serie davvero speciale, pensata per essere installata in spazi dalle dimensioni contenute. I

due nuovi frigoriferi/freezer a cassetto D20A e D30A rappresentano una profonda innovazione di tipo sia estetico che tecnologico. Questa serie offre l'ulteriore vantaggio di non disperdere il freddo anche a fronte di numerose aperture nell'arco della giornata. Dotati di pratico contenitore estraibile (BRK35 e C47), occupano spazi limitati, conservando al contempo un'ottima fruibilità.

M25, V26, V31, S44 sono frigoriferi legati a specifici brand di veicoli (rispettivamente: Mercedes, Volvo, Volvo, Scania).

PORTABLE **SPECIAL INSTALLATION**



C65L-C65D	C41L-C41D	C29M-C29D	VF65P	VF55P	VF45P	VF35P	VF16P	D20A	D30A	BRK35P	C47CHR	M25	V26	V31	S44	
65	41	29	65	55	45	35	16	20	30	35	47	25	26	31	44	
•	•	•	•	•	•	•	•	ALL-IN ONE	ALL-IN ONE	•	•	•	•	•	•	
24	17	15	23	22	20,5	19,5	8	15	17	16	19	14	14	16	16	
765	650	530	710	710	680	680	560	440	440	440	430	671	598	364	615	
510	385	345	455	455	410	410	240	445	585	520	480	451	478	486	619	
458	400	390	560	500	490	440	420	250	250	250	392	210	216	267	240	
								•	•						•	
										•	•					
												•	•	•		
•	•	•	•	•	•	•	•									
								•	•	•	•					
								•	•	•	•	•	•		•	
•	•	•	•	•	•	•	•	•	•	•	•	•	•	•	•	
•	•	•	•	•	•	•	•									
								•	•	•	•	•	•	•	•	
12/24	12/24	12/24	STANDARD					12/24	12/24	12/24	12/24	12/24	12/24	12/24	12/24	12/24
100/240	100/240	100/240	12/24 Vdc / 100/240 Vac 50/60Hz							100/240	100/240	100/240	100/240	100/240	100/240	100/240
45	43	48	55	55	55	55	45	43,5	43,5	31	31	36	36	36	36	
C65D	C41D	C29D	•	•	•	•	•	•	•							
C65L	C41L													•	•	
		C29M								•	•	•	•			
•	•	•	•	•	•	•	•									
										•						
30	31	31	36	36	37	37	37	43	43	44	45	46	46	47	47	

(*) C29D is available only as - C29D è disponibile solo in versione 12/24Vdc - 100-240Vac 50/60Hz

STRATOS



STRATOS ROOF AIR CONDITIONER FOR STATIONARY USE



ITALIAN
DESIGN



2 BLOCKS
DESIGN



ADVANCED
AERODYNAMICS



IP59
CERTIFIED



ENERGY
SAVING



EMC
CERTIFIED



HIGH COOLING
POWER



TROPICAL
USE



LIFETIME
TESTED



EXTREME
TILT



EASY
FIX

STRATOS CLIMATIZZATORE DA TETTO AD USO STAZIONARIO

STRATOS

Superior Comfort, Safety and Efficiency

COMFORT, SICUREZZA ED EFFICIENZA
DI LIVELLO SUPERIORE

The new STRATOS rooftop air conditioner provides solutions for virtually any industrial vehicle currently on the road. Designed for maximum efficiency and minimum consumption, it is the best solution for air conditioning requirements in the driver's cab.

Vitrifrigo air conditioners, powered directly by the vehicle battery, guarantee the perfect compromise between energy saving and improved comfort conditions in terms of internal air conditioning quality, dehumidification and sound emissions.

They are simple to use with flexible air flow through individually adjustable air vents which can be easily managed by the integrated control panel or remote control.

Il nuovo climatizzatore da tetto STRATOS offre soluzioni adatte praticamente a qualsiasi automezzo industriale attualmente in circolazione. Progettato per ottenere la massima efficienza e il minor consumo, rappresenta la risposta più valida alle esigenze di condizionamento all'interno della cabina guida. I climatizzatori Vitrifrigo, alimentati direttamente dalla batterie del veicolo, garantiscono il perfetto compromesso tra ridotto consumo energetico e incremento delle condizioni di benessere, inteso sia come qualità della climatizzazione e della deumidificazione interna che come livello di emissioni di rumore.

Semplici nel loro utilizzo, con flussi d'aria flessibili attraverso diffusori ruotabili singolarmente, possono essere gestiti comodamente dal pannello di controllo integrato o mediante controllo remoto.



Innovative Made in Italy Design

DESIGN INNOVATIVO MADE IN ITALY

A STRONG PERSONALITY WITH A MODERN AND ELEGANT STYLE.

Stratos uses a new self-supporting chassis and storm-proof cover: the front profile line and the reduced height favour a perfect aerodynamic penetration, thus enabling to increase fuel efficiency. Thanks to last generation compressor with inverter technology stratos offers an high efficiency and reduced power consumption. Lifetime tested, Stratos is very fast and easy to install: you can fix it in extreme tilt (up to 30°).

PERSONALITÀ DECISA DECLINATA NEL DESIGN MODERNO ED ELEGANTE.

Stratos utilizza un nuovo telaio autoportante con copertura a prova di intemperie: la linea del profilo anteriore e l'altezza ridotta favoriscono una perfetta penetrazione aerodinamica, consentendo così un deciso risparmio dei consumi di carburante. Il nuovo compressore di ultima generazione con tecnologia a inverter offre un'elevata efficienza e consumi ridotti. Testato a vita, Stratos si installa in maniera semplice e veloce, anche in situazioni in cui sia necessaria un'inclinazione decisamente elevata (fino a 30°).



Advanced Features

CARATTERISTICHE AVANZATE

Temperature setting Regolazione temperatura	●
Blower speed setting levels Livelli di regolazione velocità ventilatori	6
Operation settings: AUTO, ECO, NIGHT Programmi di regolazione potenza: AUTO, ECO, NIGHT	3
On/off switching timer Timer accensione e spegnimento	●
Auto-diagnostic function Funzione di autodiagnostica	●
Battery saving function Funzione salva batteria	●
Tilting sensor Sensore di spegnimento con cabina inclinata	●
Compressor type Tipo di compressore	24 Vdc Inverter Rotary/Rotativo
Max cooling capacity Resa frigorifera max	6000 Btu/h
Rotary air opening Numero bocchette orientabili	●

STRATOS





Fast and Easy Installation

INSTALLAZIONE SEMPLICE E VELOCE

The new Stratos is equipped with a self-supporting plastic platform designed to be installed on most popular truck brands.

- (1) After removing the roof hatch, the unit is ready to be installed together with its installation kit.
- (2) Install Stratos on the truck roof.
- (3) Set the supplied flange for completing the internal installation.

Il nuovo Stratos è dotato di un pianale portante in materiale plastico predisposto per essere montato sui camion dei marchi più diffusi.

- (1) Dopo aver rimosso la botola, è già possibile predisporre il pianale secondo le istruzioni del kit dedicato.
- (2) Installare Stratos sul tetto del camion.
- (3) Montare la cornice in dotazione per completare l'installazione.

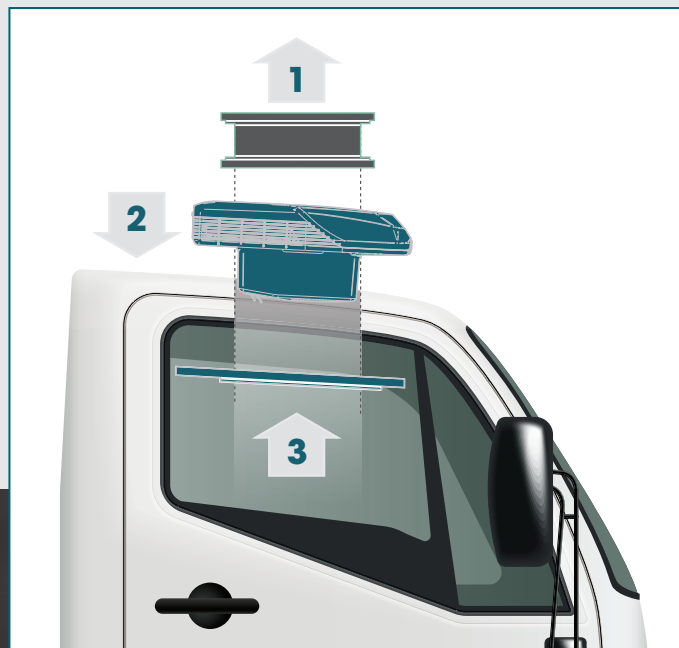

New Remote Control

NUOVO TELECOMANDO

New small size remote control with auto time set function for timed on/off switching.

By using the Stratos remote control, you can quickly access to the all functions.

You can choose AUTO, ECO, NIGHT functioning mode:

3 single settings to get the best:

- **Auto:** max performance (up to 1750 W)
- **Eco:** max operating time (more than 14 hrs)
- **Night:** very low noise level.

Nuovo telecomando di ridotte dimensioni con funzione di accensione/spegnimento temporizzato.

Mediante l'utilizzo del telecomando in dotazione, è possibile accedere rapidamente a tutte le funzioni dello Stratos.

È possibile selezionare una delle 3 modalità di funzionamento preimpostate, che garantiscono il funzionamento ottimizzato a seconda di specifiche esigenze:

- **Auto:** massimo della potenza (fino a 1750W)
- **Eco:** massimo della durata (oltre 14 ore)
- **Night:** massimo della silenziosità.

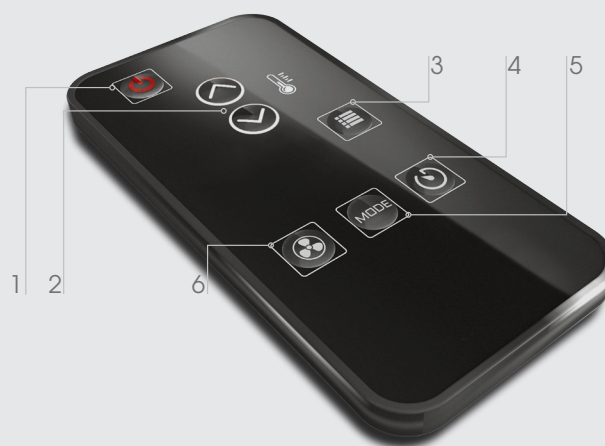

1 On/off
Accensione/spegnimento

2 Temperature control
Controllo temperatura

3 Menu
Menu

4 Timer
Timer

5 Compressor power
Potenza del compressore

6 Fan speed
Velocità dei ventilatori



Oled Display

DISPLAY OLED

NEW BRIGHT AND EASY TO USE OLED DISPLAY.

Stratos fits into the vehicle cabin in a discreet and elegant way: the anthracite gray casing houses the three adjustable vents to distribute the air flow as desired, the internal air intake grille and the new high-brightness OLED display able to set the desired functions.

NUOVO DISPLAY OLED LUMINOSO E DI SEMPLICE UTILIZZO.

Stratos si inserisce nella cabina del veicolo in maniera discreta ed elegante: l'involucro grigio antracite ospita le tre bocchette orientabili per distribuire a piacere il flusso dell'aria, il grigliato di aspirazione dell'aria interna e il nuovo display oled ad alta luminosità con il quale impostare le funzioni desiderate.



KIT BRAND

ACCESSORIES

ACCESSORI CABIN

DAF	XF XF	SpaceCab Super SpaceCab
IVECO	STRALIS STRALIS	Hi-Road Hi-Way
MERCEDES	ACTROS ACTROS	DayCab BigSpace
RENAULT	T Series T Series T Series T Series	DayCab N&D Cab SleeperCab High SleeperCab
SCANIA	R Series R Series R Series Next Generation	Standard Highline Topline
MAN	TGX	
UNIVERSAL KIT		

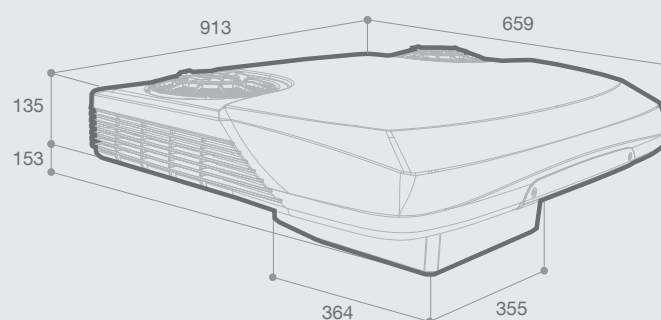

STRATOS

Cooling capacity Potenza frigorifera	6.000 Btu/h.
Net weight Peso netto	22,5 kg.
Power supply Alimentazione	24 Vdc
Refrigerant gas Gas refrigerante	R134a
Rotary air openings Bocchette orientabili	N.3

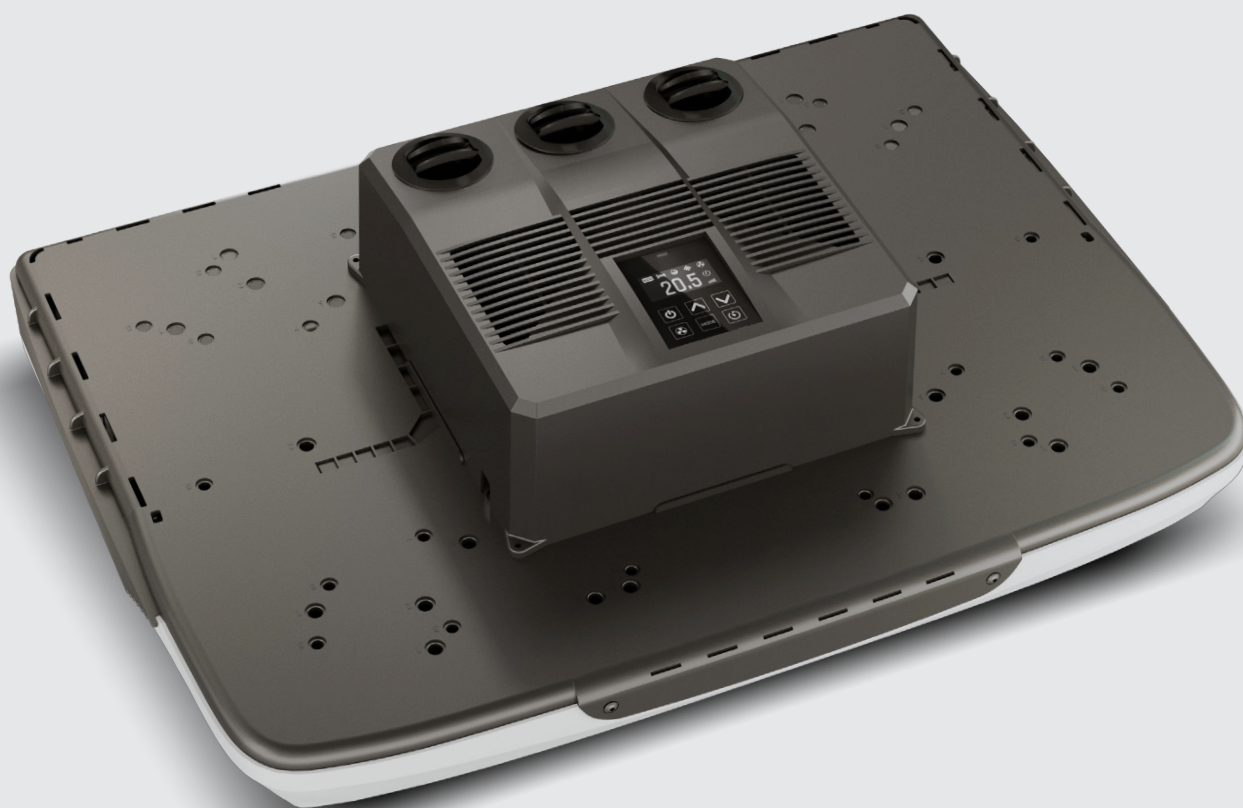

RW3000

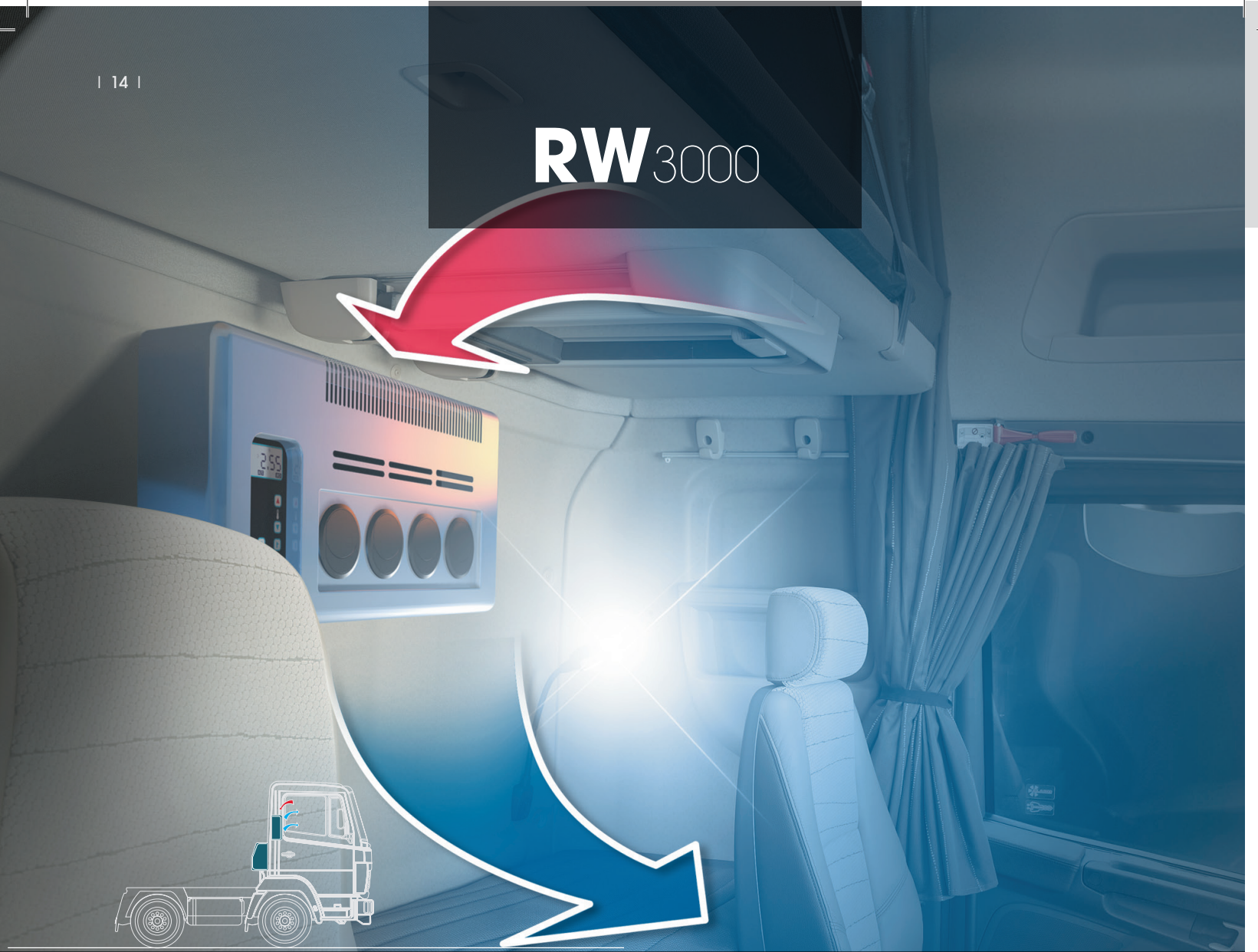

The Roadwind 3000 conditioners are one of the ultimate answers to the conditioning needs in the trucks sleeping van. The new compressor allow to use the conditioner during the night time with the engine turned off, always keeping a perfect compromise between wellness and low power consumption.

The most reduced dimension of the condensing unit, made possible its installation, on the cab wall, on the roof and on the bottom of the cab.

The installation is made easier thanks to the new connections with flexible copper and stainless steel antivibrations pipe (2 meters long), which, together with the easy quick couplings, assure safety, fast installation and quality of resistance.

Moreover, Vitfrigo is the only company present on the market to supply the conditioning system complete with precharge in each component. Evaporating unit: placed on the back wall, allows to refresh the cabin, optimizing the sleeping van conditioning.

External condensing unit: Suitably planned for the installation on the cabin rear, thanks to its reduced dimension, it's the most compact condensing unit actually present on the market.

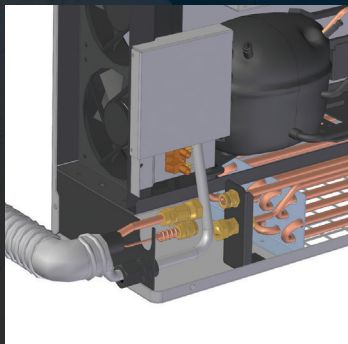

I climatizzatori Roadwind 3000 sono una delle risposte più valide alle esigenze di condizionamento nei vani cuccetta dei veicoli industriali. Il nuovo compressore permette l'utilizzo del climatizzatore durante le ore diurne e a motore spento, garantendo un perfetto compromesso tra benessere e basso consumo energetico.

Le dimensioni contenute dell'unità condensatrice, rendono possibile la sua installazione, oltre che a parete, anche a tetto e nel sottocabina.

Grazie alle nuove connessioni con tubo flessibile in rame e acciaio inox antivibrazioni (della lunghezza di 2 mt.) e agli

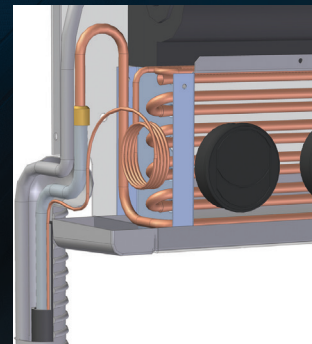

innesti rapidi, si ottiene sicurezza, rapidità d'installazione e qualità di tenuta. Vitfrigo è, inoltre, l'unica azienda attualmente sul mercato a fornire l'impianto condizionante precaricato in ogni suo componente. Unità evaporante: posizionata sulla parete posteriore, permette di rinfrescare la cabina, ottimizzando il condizionamento della zona cuccetta.

Unità condensatrice esterna: studiata per l'installazione sul retro della cabina, è l'unità condensatrice più compatta attualmente presente sul mercato.

ROADWIND WALL AIR CONDITIONER FOR STATIONARY USE

ROADWIND CLIMATIZZATORE DA PARETE AD USO STAZIONARIO

RW3000

Cooling capacity Potenza frigorifera	3.000 Btu/h.
Net weight Peso netto	6 kg. (A) + 19 kg. (B)
Power supply Alimentazione	24 Vdc
Refrigerant gas Gas refrigerante	R134a
Rotary air openings Bocchette orientabili	N.4

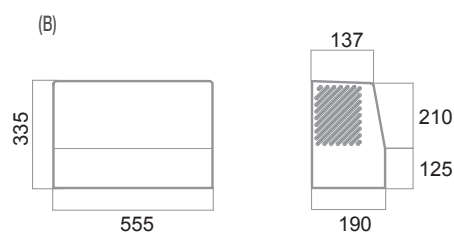
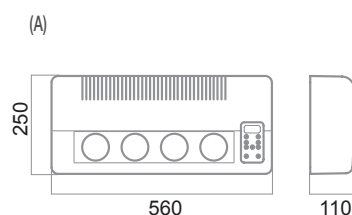

CONTROL PANEL MICROCHIP DRIVEN WITH
BACKLIGHT DISPLAY LCD FOR DIGITAL DISPLAY OF:

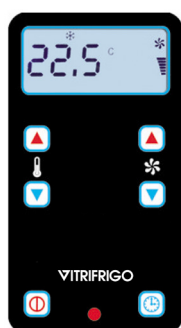

- Ambient temperature
- Humidity
- Battery
- Switch off timer (0/360 minutes)
- Compressor state (ON/OFF)
- Ventilation setting on 4 levels
- Temperature setting
- Battery saving function
- 4 Rotary air openings

PANNELLO COMANDI A MICROPROCESSORE CON DISPLAY
LCD RETRO ILLUMINATO CON VISUALIZZAZIONE DIGITALE DI:

- Temperatura ambiente
- Umidità
- Tensione di batteria.
- Timer di spegnimento (0/360 min.)
- Stato compressore (ON/OFF)
- Regolazione ventilazione su 4 livelli
- Regolazione temperatura
- Funzione salva batteria
- 4 bocchette orientabili

Remote control
Telecomando



CHROMELOCK SERIES



FRIDGES AND FREEZERS

WITH BUILT-IN/REMOTE COOLING UNIT

FRIGORIFERI E FREEZER

CON UNITÀ INTERNA/ESTERNA

Available models Modelli disponibili	Total volume Capacità totale			
BUILT-IN COOLING UNIT / UNITÀ INTERNA				
C62i CHR	62	●		
C60i CHR	60	●	●	
C51i CHR	51	●		
C51DW CHR	51	●		●
C50i CHR	50	●	●	
C39i CHR	39	●	●	
REMOTE COOLING UNIT / UNITÀ ESTERNA				
C42L CHR	42	●	●	
C42DW CHR	42		●	●
C25L CHR	25		●	

 Fridge/Freezer
Frigo/Congelatore

 Only fridge
Solo frigo

 Drawer
Cassetto



The new complete range

LA NUOVA GAMMA COMPLETA

The Chromelock series is the new complete range that covers every requirement in terms of space and capacity. Ergonomic, quiet, intuitive and safe, it is able to guarantee maximum on-board comfort.

La serie Chromelock è la nuova gamma completa che copre tutte le esigenze in termini di spazio e di capacità. Ergonomica, silenziosa, intuitiva e sicura, è in grado di garantire il massimo del comfort a bordo.

FRIDGES AND FREEZERS

WITH BUILT-IN/REMOTE COOLING UNIT

FRIGORIFERI E FREEZER

CON UNITÀ INTERNA/ESTERNA

INNOVATION BELONGS TO THOSE WITH A HISTORY.

Chromelock is the evolution of a high-profile design and production experience, able to combine technological innovation and design, with the functionality and quality of Made in Italy, in the search for a unique style that successfully combines essential elegance, quality value and unique personality.

L'INNOVAZIONE APPARTIENE A CHI HA UNA STORIA.

Chromelock è l'evoluzione di un'esperienza progettuale e produttiva di alto profilo, in grado di abbinare l'innovazione tecnologica e il design, con la funzionalità e la qualità del Made in Italy, nella ricerca di uno stile unico che sa unire eleganza essenziale, valore della qualità, personalità distintiva.



INCREASED DOOR THICKNESS
ANTA A SPESSORE MAGGIORATO



ANTI-FINGERPRINT AND SCRATCH RESISTANT
FINISH WITH SOFT TOUCH EFFECT
FINITURA ANTI IMPRONTA ED ANTIGRAFFIO
CON EFFETTO SOFT TOUCH



REPLACEABLE SEAL
GUARNIZIONE SOSTITUIBILE



METAL FINISH HANDLE
MANIGLIA CON FINITURA
METALLIZZATA



VENT POSITION SYSTEM
SISTEMA VENT POSITION





Form always follows function

LA FORMA SEGUE SEMPRE LA FUNZIONE

THE NEW DOOR

- lighter with the same overall dimensions and totally built-in, with a smooth and elegant side frame, 42 mm thick.
- reversible and available in two colour variants: grey (Light) and black (Dark). The Light version has an elegant glossy grey laminated panel with a pearly effect, while in the Dark version the panel is matt black with anti-fingerprint and scratch resistant finish with soft touch effect.
- possibility to use finishing panels from 0.8 to 3.0 mm thick, guaranteeing simple and ultra-fast installation
- removable seal for its replacement and cleaning

THE NEW CHROMELOCK HANDLE

- elegant metal finish tested for over 150,000 opening and closing cycles
- carries out a positive and safe closing of the door
- integrated "vent position"

LA NUOVA PORTA

- più leggera a parità di ingombro e incasso totale, con un profilo laterale liscio ed elegante da 42 mm. di spessore
- reversibile e disponibile in due varianti cromatiche grigia (Light) e nera (Dark). La versione Light ha un elegante pannello laminato grigio lucido ad effetto perlato, mentre nella versione Dark il pannello è nero opaco con finitura anti impronta ed antigraffio con effetto soft touch.
- possibilità di utilizzare pannelli di finitura con spessori da 0,8 a 3,0 mm., per un'installazione semplice e ultrarapida
- guarnizione estraibile per la sua sostituzione e pulizia

LA NUOVA MANIGLIA CHROMELOCK

- elegante finitura metallizzata testata per oltre 150.000 cicli di apertura e chiusura
- effettua una chiusura positiva e sicura della porta
- "vent position" incorporata

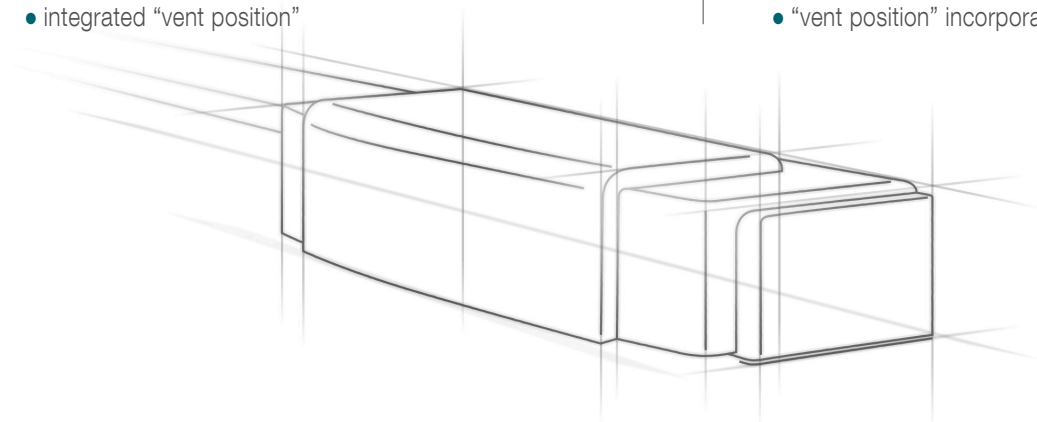



Chromelock: the smart locking system

CHROMELOCK: IL SISTEMA DI CHIUSURA INTELLIGENTE

The Chromelock system allows secure locking of the door even during intensive and extreme use of your boat.

Il sistema Chromelock permette il bloccaggio sicuro della porta anche durante l'uso intensivo ed estremo della vostra imbarcazione.



INTEGRATED VENT POSITION SISTEMA DI VENTILAZIONE INTEGRATO

A practical device incorporated in the Chromelock handle performs the "vent position" function, allowing the door to be held ajar, thus avoiding the formation of mould and odours during periods of non-use.

Un pratico dispositivo inglobato nella maniglia Chromelock realizza la funzione di "vent position", consentendo il mantenimento della porta in posizione socchiusa, evitando così la formazione di muffe e odori nei periodi di non utilizzo.

STANDARD



Double door colouring

DOPPIA COLORAZIONE DELLA PORTA



The series is available in grey or black, to best respond to the customisation needs of your cabin.



La serie è disponibile in colorazione grigia o in colorazione nera, per rispondere in maniera ottimale alle esigenze di personalizzazione della vostra cabina.



Replaceable finishing panel

PANNELLO DI FINITURA SOSTITUIBILE



Finishing panels from 0.8 mm to 3.0 mm thick. Replace the panel quickly and easily using (1) interlocking flange, without the use of tools and screws.

Pannelli di finitura con spessori da 0,8 mm. a 3,0 mm. Sostituzione del pannello facile e veloce tramite (1) profilo ad incastro, senza l'uso di utensili e viti.



FRIDGE + FREEZER
FRIGORIFERO + FREEZER



FRIDGE
FRIGORIFERO



DRAWER
CASSETTO



OPTIONAL (Mounting flange / Profilo di fissaggio)



Door Inside
PORTA A FILO INTERNO



Door Outside
PORTA A FILO ESTERNO



The entire series can be installed by means of a mounting flange (optional), which by simply sliding it forward or back, allows both the totally built-in version (door inside) and the partially built-in version (door outside).

Tutta la serie ha la possibilità di essere installata mediante un profilo di fissaggio (optional), che permette tramite il suo semplice scorrimento in avanti o indietro sia la versione a incasso totale (door inside) che quella a incasso parziale (door outside).



Remotable cooling unit
UNITÀ DI REFRIGERAZIONE REMOTABILE

Up to **1,5**
FINO A **mt.**

The remotable external cooling unit offers added available volume inside the refrigerator. In addition, it expands the installation possibilities in terms of functionality, efficiency and soundproofing.

L'unità di refrigerazione esterna remotabile permette di avere maggior volume a disposizione all'interno del frigorifero. Inoltre, espande le possibilità di installazione, sia in termini di funzionalità che di efficienza e insonorizzazione.

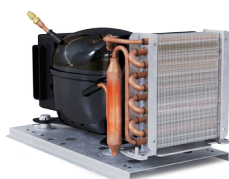

Dual electronic control
CENTRALINA BIVALENTE

12/24 Vdc - 100/240 Vac
50/60 Hz





Fridge
Freezer

OPTIONAL
12/24Vdc
100/240Vac

C62i CHR

Total volume Capacità totale	62 lt.
Freezer compartment Vano freezer	4,5 lt.
Net weight Peso netto	16,8 kg.
Power supply and nominal consumption Alimentazione e consumo nominale	12/24 Vdc 40 W

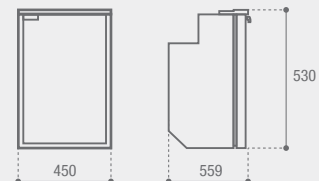

OPTIONAL
Fridge

Fridge
Freezer

OPTIONAL
12/24Vdc
100/240Vac

C60i CHR

Total volume Capacità totale	60
Freezer compartment Vano freezer	10,2 lt.
Net weight Peso netto	18,6 kg.
Power supply and nominal consumption Alimentazione e consumo nominale	12/24 Vdc 40 W

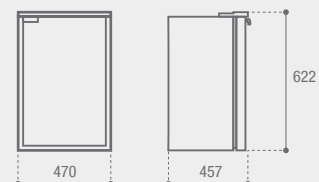



Fridge
Freezer

OPTIONAL
12/24Vdc
100/240Vac

C51i CHR

Total volume Capacità totale	51 lt.
Freezer compartment Vano freezer	3,6 lt.
Net weight Peso netto	16 kg.
Power supply and nominal consumption Alimentazione e consumo nominale	12/24 Vdc 40 W

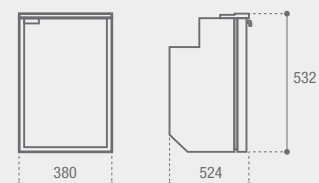

 H max
250 mm.



Fridge
Freezer

OPTIONAL
12/24Vdc
100/240Vac

C51DW CHR

Total volume Capacità totale	51 lt.
Freezer compartment Vano freezer	3,6 lt.
Net weight Peso netto	19 kg.
Power supply and nominal consumption Alimentazione e consumo nominale	12/24 Vdc 40 W

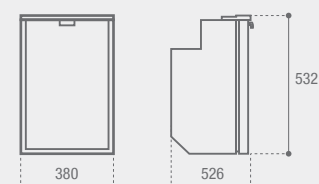



OPTIONAL
Fridge

Fridge
Freezer

OPTIONAL
12/24Vdc
100/240Vac

C50i CHR

Total volume Capacità totale	50 lt.
Freezer compartment Vano freezer	3,6 lt.
Net weight Peso netto	15,7 kg.
Power supply and nominal consumption Alimentazione e consumo nominale	12/24 Vdc 40 W

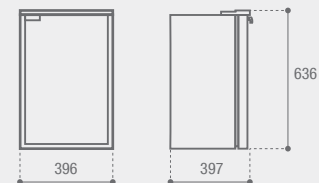

OPTIONAL
Fridge

Fridge
Freezer

OPTIONAL
12/24Vdc
100/240Vac

C39i CHR

Total volume Capacità totale	39 lt.
Freezer compartment Vano freezer	3,6 lt.
Net weight Peso netto	16 kg.
Power supply and nominal consumption Alimentazione e consumo nominale	12/24 Vdc 31 W

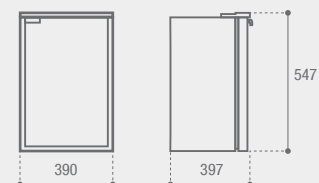

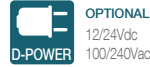

C42L CHR

Total volume Capacità totale	42 lt.
Freezer compartment Vano freezer	3,6 lt.
Net weight Peso netto	15 kg.
Power supply and nominal consumption Alimentazione e consumo nominale	12/24 Vdc 31 W

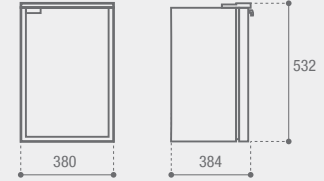

H max
420 mm.



C42DW CHR

Total volume Capacità totale	42 lt.
Net weight Peso netto	18 kg.
Power supply and nominal consumption Alimentazione e consumo nominale	12/24 Vdc 31 W

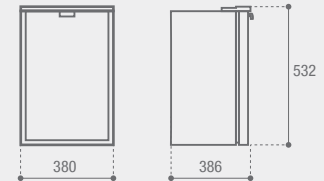

C25L CHR

Total volume Capacità totale	25 lt.
Net weight Peso netto	12 kg.
Power supply and nominal consumption Alimentazione e consumo nominale	12/24 Vdc 34 W

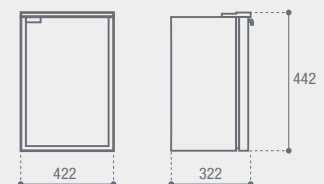

PORTABLES



PORTABLES

FRIDGES AND FREEZERS

PORTATILI

FRIGORIFERI E FREEZER

Available models Modelli disponibili	Total volume Capacità totale
C65L - C65D	65 lt.
C41L - C41D	41 lt.
C29M - C29D	29 lt.

VFREE SERIES

VF65P	65 lt.
VF55P	55 lt.
VF45P	45 lt.
VF35P	35 lt.
VF16P	16 lt.



Superior portability

PORTABILITÀ DI LIVELLO SUPERIORE

The portable refrigerators and freezers by Vitrifrigo offer excellent portability features, both in terms of reduced consumption and operational silence, and in terms of range and speed of reaching the desired temperature. Efficiency, versatility and compactness: with capacities ranging from 16 to 65 litres, they are a valid alternative to a traditional fridge/freezer.

I frigoriferi e freezer portatili Vitrifrigo offrono eccellenti caratteristiche di portabilità, sia in consumi ridotti e di silenziosità operativa che in termini di range e velocità di raggiungimento della temperatura desiderata. Efficienza, versatilità e compattezza: con capacità che vanno da 16 fino a 65 litri, rappresentano una valida alternativa ad un frigo/freezer di tipo tradizionale.



Bring them everywhere!

PORTATELI OVUNQUE!

Portable refrigerators provide foldable handles for easy carrying. Handles are installed, using sturdy metal pins, to avoid sudden breakage.

Comfort and safety are, once more, an indispensable combination.

I frigoriferi portatili sono dotati di serie di maniglie per un agevole trasporto.

Per i modelli con maniglie pieghevoli, il fissaggio e la rotazione di queste ultime avviene mediante robusti perni in acciaio che mettono al riparo da rotture improvvise. Comfort e sicurezza sono, ancora una volta, un binomio indissolubile.



Temperature under control

TEMPERATURA SOTTO CONTROLLO

Depending on the type of portable refrigerator, there are thermostat choices for the maintenance of desired internal temperatures.

A seconda della tipologia di frigorifero portatile è possibile scegliere la soluzione che più si addice alle esigenze personali, per mantenere la temperatura interna del frigorifero costantemente monitorata.

(a) Termostato meccanico / Mechanical thermostat

(b) Termostato a Led / LED thermostat

(c) Termostato digitale / Digital thermostat





Organize your free time

ORGANIZZATE IL VOSTRO TEMPO LIBERO

Portable refrigerators are equipped with a removable coated wire basket that is useful for loading and removing food and drinks easily.

The standard locking bracket allows to keep the refrigerator in place while underway (except for C65).

A 12Vdc cord is supplied for connecting the refrigerator to the car battery.

I frigoriferi portatili sono dotati di serie di un pratico cestello interno removibile a fili d'acciaio, estremamente utile per introdurre o estrarre facilmente tutto il contenuto del frigorifero.

La staffa di fissaggio in dotazione standard dà la possibilità di ancorare saldamente e velocemente il frigorifero in uno spazio predeterminato (eccetto C65).

In dotazione anche il cavo per l'alimentazione a batteria, con la presa universale per l'accendisigari.

Removable basket - Cestello removibile



Locking bracket - Staffa di fissaggio



12Vdc plug - Presa per alimentazione a 12 Vdc



Internal led light - Luce interna a Led



°C + 10 - 20



C65L - C65D

Total volume
Capacità totale 65 lt.

Net weight
Peso netto 24 kg.

Power supply and
nominal consumption 12/24 Vdc
Alimentazione e
consumo nominale 45 W

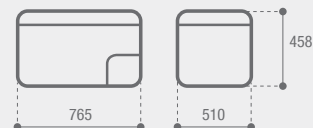

OPTIONAL
12/24Vdc
D-POWER 100/240Vac

C65L - LED thermostat - Termostato a Led
C65D - Digital thermostat - Termostato digitale





°C + 10 - 10



OPTIONAL
12/24Vdc
D-POWER 100/240Vac

C41L - C41D

Total volume Capacità totale	41 lt.
Net weight Peso netto	17 kg.
Power supply and nominal consumption Alimentazione e consumo nominale	12/24 Vdc 43 W

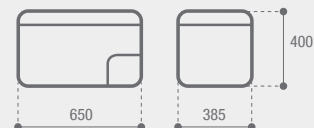

C41L - LED thermostat - Termostato a Led
C41D - Digital thermostat - Termostato digitale



°C + 10 - 15



OPTIONAL
12/24Vdc
D-POWER 100/240Vac

C29M - C29D

Total volume Capacità totale	29 lt.
Net weight Peso netto	15 kg.
Power supply and nominal consumption Alimentazione e consumo nominale	12/24 Vdc 48 W



C29M - Mech. thermostat - Termostato mecc.
C29D - Digital thermostat - Termostato digitale

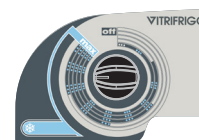

C29M



C29D

C29D is available only as 12/24Vdc - 100-240Vac 50/60Hz

C29D è disponibile solo in versione 12/24Vdc - 100-240Vac 50/60Hz

PORTABLES
FRIDGES AND FREEZERS

FRIGORIFERI E FREEZERS
PORTATILI





ALL THE CAPACITY YOU NEED

TUTTA LA CAPIENZA CHE TI SERVE

The VFREE series ensures ideal cooling performance even at extremely high ambient temperatures, thanks to the use of state-of-the-art compressors, with extremely low energy consumption. From the smallest of the range, the VF16P featuring 16 litres of lightness, usable in a wide variety of recreational situations, up to the generous VF65P, offering 65 litres, perfectly capable of replacing a traditional type refrigerator, the Vfree series offers refrigeration and freezing from +10 up to -22°C with operation at 12Vdc or 220-240Vac combined with extremely reduced consumption, thereby making it an excellent travel companion even in the presence of a photovoltaic system.

La serie VFREE assicura prestazioni di raffreddamento ideali anche a temperature ambiente estremamente elevate, grazie all'utilizzo di compressori di ultima generazione, a fronte di un consumo energetico estremamente basso. Dal più piccolo della serie, il VF16P, 16 litri di leggerezza, utilizzabile nelle più svariate situazione tipiche del tempo libero, sino al generoso VF65P, un 65 litri, capace di sostituire in maniera perfetta anche un frigorifero di tipo tradizionale, la serie Vfree offre refrigerazione e congelazione da +10 sino a -22 °C con funzionamento a 12Vdc o 220-240Vac a fronte di consumi davvero ridotti, sì da farne un compagno di viaggio eccellente anche in presenza di impianto fotovoltaico.





Practicality is not an optional!

LA PRATICITÀ NON È UN OPTIONAL

The VFREE series has been designed to offer maximum practicality in daily use:

- two sturdy handles facilitate lifting and transportation (the VF16P is equipped with a handy strap for carrying on the shoulder);
- the lid can be opened on both sides and, if necessary, is completely removable (with the exception of the VF16P);
- the basket is removable and its internal volume can be compartmentalised to optimise the storage of food and drinks (with the exception of the VF16P);
- a wide range of usable power supplies: from 12/24Vdc to 100/240Vac 50/60Hz;
- the interior lighting with high brightness blue LEDs allows use of the fridge in situations of complete darkness.

La serie VFREE è stata pensata per offrire il massimo della praticità nell'utilizzo quotidiano:

- due robusti maniglioni agevolano il sollevamento e il trasporto (il VF16P ha in dotazione una tracolla per il trasporto a spalla);
- il coperchio è apribile da entrambi i lati e, all'occorrenza, completamente amovibile (ad eccezione del VF16P);
- il cestello è estraibile e il suo volume interno divisibile per ottimizzare lo stivaggio di cibo e bevande (ad eccezione del VF16P);
- un ampio range di alimentazioni utilizzabili: da 12/24Vdc a 100/240Vac 50/60Hz;
- l'illuminazione interna a led azzurrati ad alta luminosità consente l'utilizzo del frigo in situazioni di totale assenza di luce.



Precise and total control

CONTROLLO PRECISO E TOTALE

The digital control panel allows quick access to the functions of the VFREE series: all information regarding the temperature set points are shown on the high brightness LED display.

A convenient USB socket is available for a direct power supply and for the charging of devices such as smartphones, tablets, etc.

In addition, the "Emergency override" function automatically blocks the thermostat in the event of a malfunction, allowing the fridge to operate in complete autonomy.

Il pannello di controllo digitale consente il rapido accesso alle funzioni della serie VFREE: tutte le informazioni relativamente ai set point della temperatura vengono visualizzate sul display led ad alta luminosità.

Disponibile una comoda presa USB per l'alimentazione e la ricarica diretta di dispositivi quali smartphone, tablet, ecc.

Inoltre, la funzione "Emergency override" blocca automaticamente il termostato in caso di malfunzionamento, lasciando che il frigo funzioni in completa autonomia.



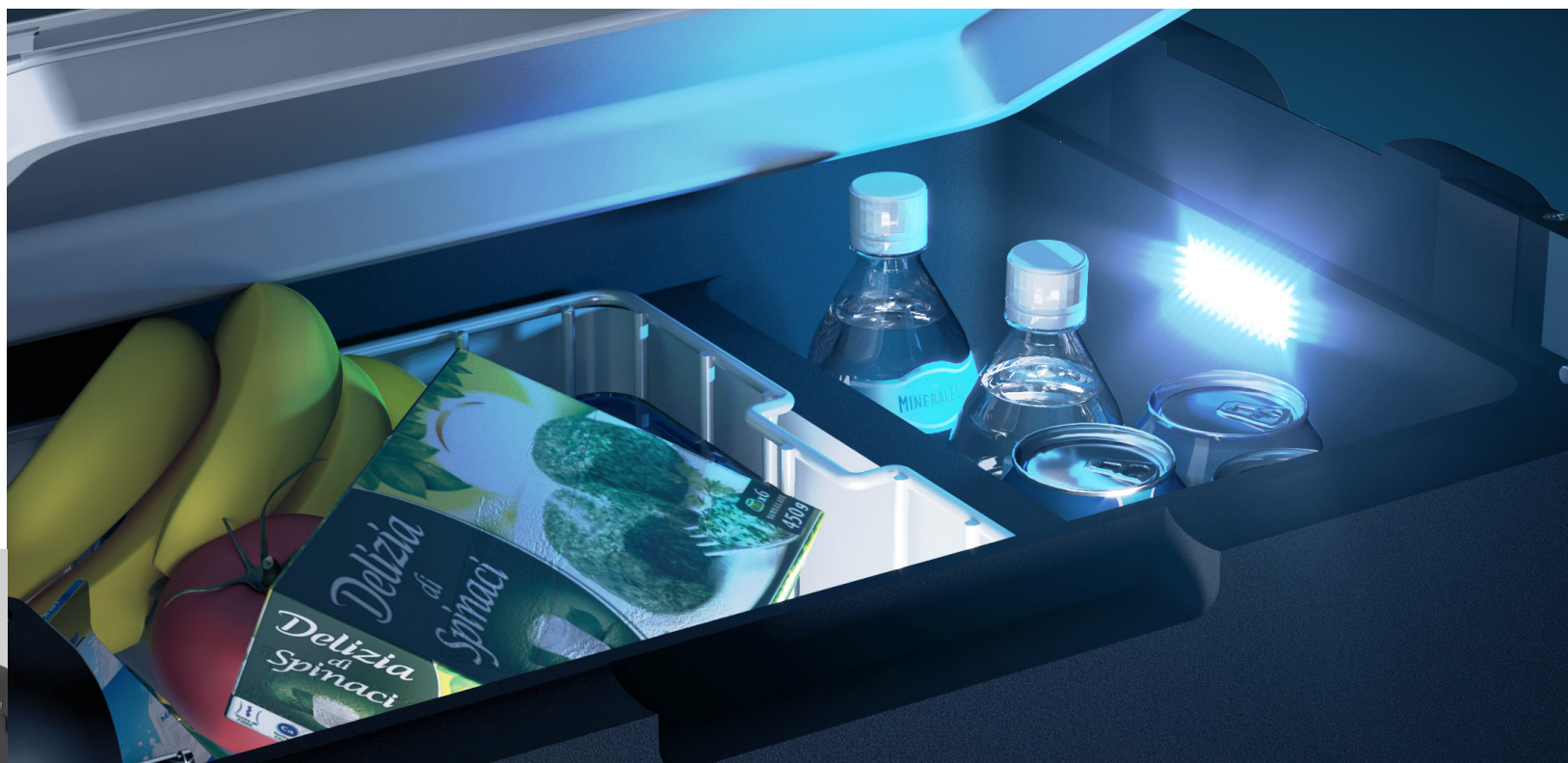

Full set of accessories

RICCA DOTAZIONE DI ACCESSORI

The VFREE series has an interior divided into two compartments with varying capacity, thus offering a practical and smart way to contain products that need to be stored fresh.

VF35P - VF45P - VF55P - VF65P

Internal view - vista dell'interno

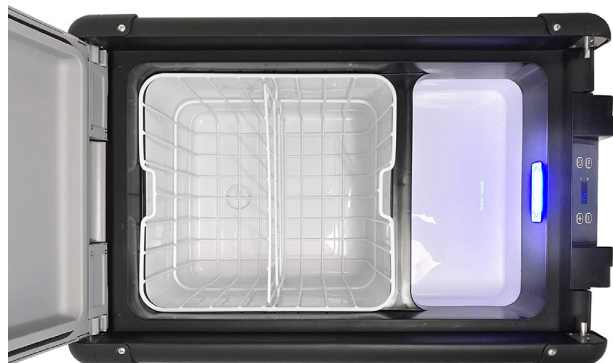

Power supply cable - Cavi per il collegamento alla rete elettrica



La serie VFREE ha l'interno suddiviso in due scomparti a capienza differente, suggerendo così una modalità pratica e intelligente circa l'alloggiamento dei prodotti da conservare al fresco.

VF16P

Internal view - vista dell'interno



shoulder bag - tracolla
external power supply - alimentatore esterno





°C + 10 - 22

VF65P



Total volume Capacità totale	65 lt.
Net weight Peso netto	23 kg.
Power supply and nominal consumption Alimentazione e consumo nominale	12/24 Vdc 100/240Vac 50/60Hz 55 W



°C + 10 - 22

VF55P



Total volume Capacità totale	55 lt.
Net weight Peso netto	22 kg.
Power supply and nominal consumption Alimentazione e consumo nominale	12/24 Vdc 100/240Vac 50/60Hz 55 W





°C + 10 - 22

VF45P



Total volume Capacità totale	45 lt.
Net weight Peso netto	20,5 kg.
Power supply and nominal consumption Alimentazione e consumo nominale	12/24 Vdc 100/240Vac 50/60Hz 55 W



°C + 10 - 22

VF35P



Total volume Capacità totale	35 lt.
Net weight Peso netto	19,5 kg.
Power supply and nominal consumption Alimentazione e consumo nominale	12/24 Vdc 100/240Vac 50/60Hz 55 W



°C + 10 - 18

VF16P



Total volume Capacità totale	16 lt.
Net weight Peso netto	8 kg.
Power supply and nominal consumption Alimentazione e consumo nominale	12/24 Vdc 100/240Vac 50/60Hz 45 W

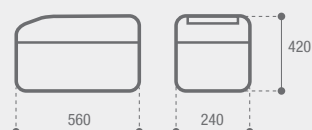

SPECIAL INSTALLATIONS



SPECIAL INSTALLATIONS

COMPACT DRAWER
FRIDGES AND FREEZERS

INSTALLAZIONI SPECIALI

FRIGORIFERI E FREEZER
COMPATTI A CASSETTO

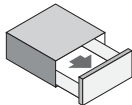
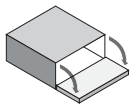
Available models Modelli disponibili	Total volume Capacità totale	
	LT.	
D20A	20	
D30A	30	
BRK35P	35	
C47 CHR	47	
M25	25	MERCEDES
V26	26	VOLVO
V31	31	VOLVO
S44	44	SCANIA



Special...from any point of view

SPECIALI... SOTTO OGNI PUNTO DI VISTA.

A very special series, designed to be installed in compact spaces. The two new D20A and D30A drawer refrigerators/freezers represent a revolutionary innovation in terms of both aesthetics and technology.

The drawer refrigerators for special installations offer the additional advantage of not dispersing the cold even with numerous openings throughout the day.

Equipped with a practical removable container (BRK35 and C47), they occupy limited space, while maintaining excellent usability.

Una serie davvero speciale, pensata per essere installata in spazi dalle dimensioni contenute.

I due nuovi frigoriferi/freezer a cassetto D20A e D30A rappresentano una profonda innovazione di tipo sia estetico che tecnologico.

I frigoriferi per le installazioni speciali a cassetto offrono l'ulteriore vantaggio di non disperdere il freddo anche a fronte di numerose aperture nell'arco della giornata.

Dotati di pratico contenitore estraibile (BRK35 e C47), occupano spazi limitati, conservando al contempo un'ottima fruibilità.

SPECIAL INSTALLATIONS

COMPACT DRAWER
REFRIGERATORS AND FREEZERS

INSTALLAZIONI SPECIALI

FRIGORIFERI E FREEZER
COMPATTI A CASSETTO

NEW

YOU DECIDE.
ANY TEMPERATURE
ANY TIME.



R600a

NATURAL GAS COMPRESSORE
COMPRESSOR GAS NATURALE





D20A and D30A: complete innovation

D20A E D30A INNOVAZIONE A 360 GRADI

D20A and D30A are compact drawer fridges/freezers, suitable for small spaces.

Designed using specific components for automotive applications, D20A and D30A are used to set any temperature, at any time.

For example, start in fridge mode and then switch to freezer mode or vice-versa.

Available in black and/or white, the D20A and D30A have an elegant and refined finish that is harmoniously suited to any interior.

D20A e D30A sono dei frigoriferi/congelatori compatti a cassetto, adatti a piccoli spazi.

Progettati utilizzando componenti specifici per applicazioni automobilistiche, D20A e D30A consentono di settare qualsiasi temperatura, in qualsiasi momento.

Si può iniziare in modalità frigo per poi passare alla modalità congelatore o viceversa.

Disponibili nella versione nera e/o bianca, D20A e D30A hanno una finitura elegante e raffinata che ben si adatta a qualsiasi interno.



FRESH



FROZEN

FRIDGE + FREEZER

FRESH AND FROZEN FOOD AND BEVERAGE



Advanced functions

FUNZIONI AVANZATE

The D20A and D30A are controlled by a digital thermostat, ensuring precise management of both temperature settings and optimisation of compressor operation, balancing efficiency and consumption combined with noise reduction during night hours.

D20A e D30A sono controllati da un termostato digitale per la gestione precisa sia dei settaggi della temperatura che dell'ottimizzazione del funzionamento del compressore, bilanciandone rendimento e consumi in funzione della riduzione del rumore durante le ore notturne.

NIGHT MODE

SMART CONTROL FOR HIGH LEVEL COMFORT



LOW NOISE



MAXIMUM ENERGY SAVING



Remotable cooling unit

UNITÀ DI REFRIGERAZIONE REMOTABILE

With the D20/30A series you are finally free to maximise any space. The remotable external cooling unit offers added available volume inside the refrigerator. In addition, it expands the installation possibilities in terms of functionality, efficiency and soundproofing.

Con la serie D20/30A si è finalmente liberi di sfruttare al massimo qualsiasi spazio. L'unità di refrigerazione esterna remotabile permette di avere maggior volume a disposizione all'interno del frigorifero. Inoltre, espande le possibilità di installazione, sia in termini di funzionalità che di efficienza e insonorizzazione.



UP TO
FINO A
1,5 mt.

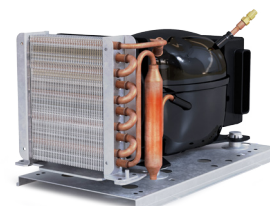

D20A

NEW



Total volume Capacità totale	20 lt.
Net weight Peso netto	15 kg.
Power supply and nominal consumption Alimentazione e consumo nominale	12/24 Vdc 43,5 W



H max
155 mm.



D30A

NEW



Total volume Capacità totale	30 lt.
Net weight Peso netto	17 kg.
Power supply and nominal consumption Alimentazione e consumo nominale	12/24 Vdc 43,5 W



H max
155 mm.





BRK35P

Total volume Capacità totale	35 lt.
Net weight Peso netto	16 kg.
Power supply and nominal consumption Alimentazione e consumo nominale	12/24 Vdc 31 W



D-POWER OPTIONAL
12/24Vdc
100/240Vac



Nuovo sistema di chiusura PUSH-TURN
New PUSH-TURN locking system

**C47 CHR**

Total volume Capacità totale	47 lt.
Net weight Peso netto	19 kg.
Power supply and nominal consumption Alimentazione e consumo nominale	12/24 Vdc 31 W

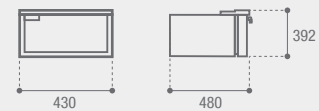

OPTIONAL
12/24Vdc
100/240Vac



M25

Total volume
Capacità totale 25 lt.

Net weight
Peso netto 14 kg.

Power supply and
nominal consumption 12/24 Vdc
Alimentazione e
consumo nominale 36 W

Suitable for
Specifico per **Mercedes-Benz**

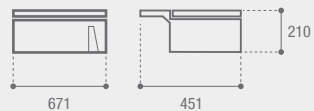

D-POWER OPTIONAL
12/24Vdc
100/240Vac



Maniglia non inclusa
Handle not included

V26

Total volume
Capacità totale 26 lt.

Net weight
Peso netto 14 kg.

Power supply and
nominal consumption 12/24 Vdc
Alimentazione e
consumo nominale 36 W

Suitable for
Specifico per **Volvo**

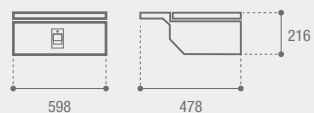

D-POWER OPTIONAL
12/24Vdc
100/240Vac

V31

Total volume
Capacità totale 31 lt.

Net weight
Peso netto 16 kg.

Power supply and
nominal consumption 12/24 Vdc
Alimentazione e
consumo nominale 36 W

Suitable for
Specifico per **Volvo**

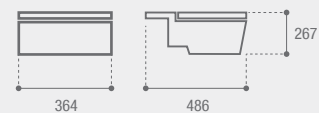

D-POWER OPTIONAL
12/24Vdc
100/240Vac



Removable lid
Coperchio amovibile



S44

Total volume
Capacità totale 44 lt.

Net weight
Peso netto 16 kg.

Power supply and
nominal consumption 12/24 Vdc
Alimentazione e
consumo nominale 36 W

Suitable for
Specifico per **Scania**



D-POWER OPTIONAL
12/24Vdc
100/240Vac



TECHNICAL DRAWINGS

DISEGNI TECNICI

CHROMELOCK SERIES

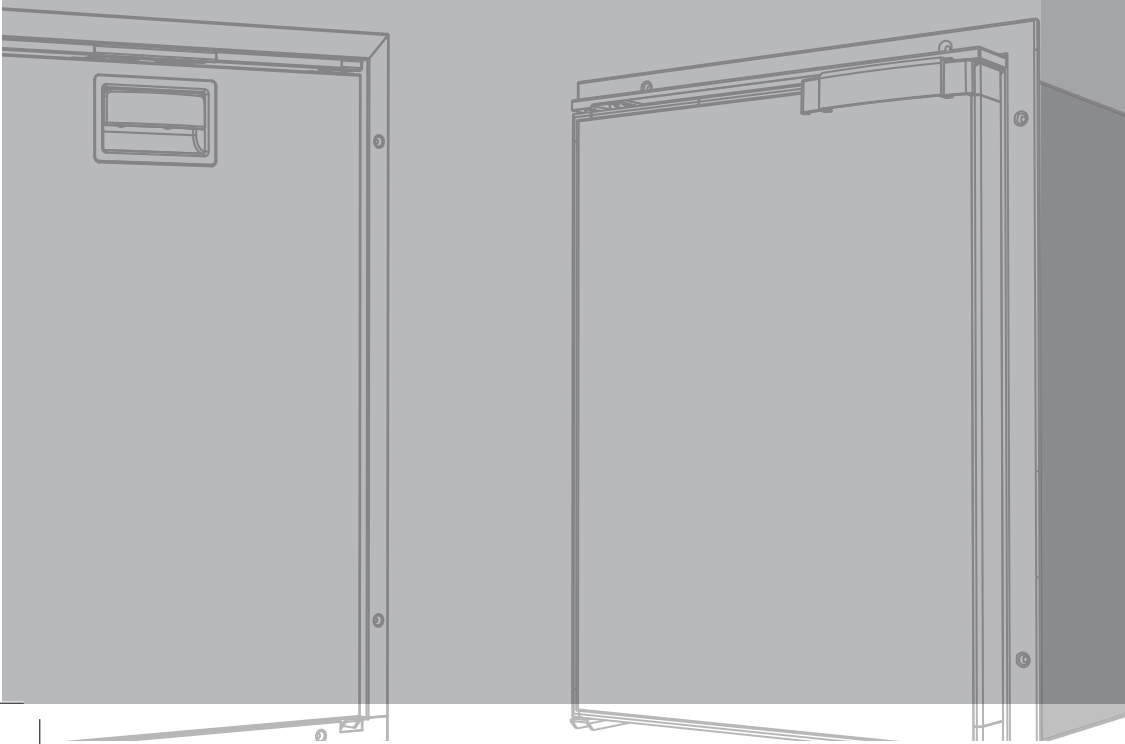
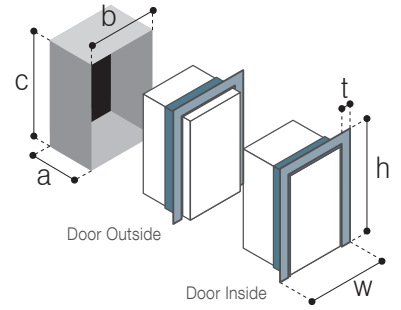

C62i CHR

pag. 22

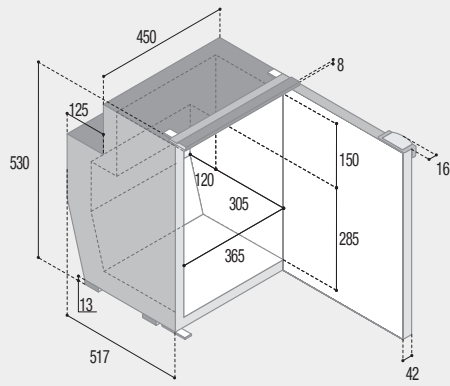

	DOOR	INSIDE	OUTSIDE
MOUNTING FLANGE PROFILO DI FISSAGGIO	t: 25	25	
	w: 513	513	
	h: 568	568	
BUILT-IN VANO INCASSO	a: 554	512	
	b: 465	465	
	c: 533	533	

C60i CHR

pag. 22

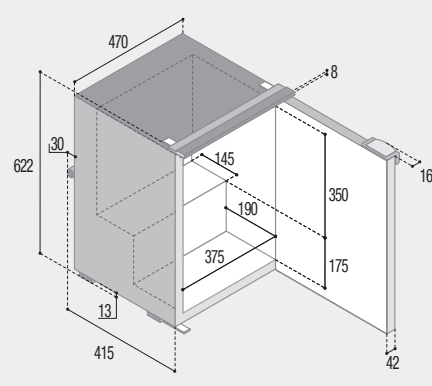

	DOOR	INSIDE	OUTSIDE
MOUNTING FLANGE PROFILO DI FISSAGGIO	t: 25	25	
	w: 533	533	
	h: 659	659	
BUILT-IN VANO INCASSO	a: 453	410	
	b: 485	485	
	c: 623	623	

C51i CHR

pag. 23

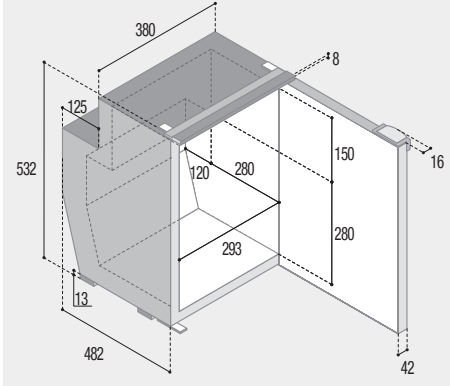

	DOOR	INSIDE	OUTSIDE
MOUNTING FLANGE PROFILO DI FISSAGGIO	t: 25	25	
	w: 443	443	
	h: 569	569	
BUILT-IN VANO INCASSO	a: 519	477	
	b: 395	395	
	c: 533	533	

C51DW CHR

pag. 23

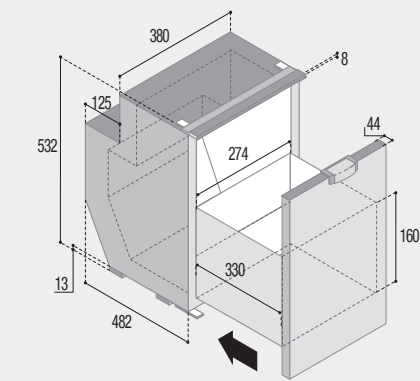

	DOOR	INSIDE	OUTSIDE
MOUNTING FLANGE PROFILO DI FISSAGGIO	t: 25	25	
	w: 443	443	
	h: 569	569	
BUILT-IN VANO INCASSO	a: 519	477	
	b: 395	395	
	c: 533	533	

C50i CHR

pag. 24

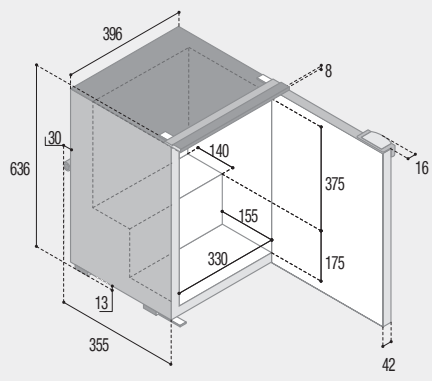

	DOOR	INSIDE	OUTSIDE
MOUNTING FLANGE PROFILO DI FISSAGGIO	t: 25	25	
	w: 459	459	
	h: 674	674	
BUILT-IN VANO INCASSO	a: 393	350	
	b: 411	411	
	c: 638	638	

C39i CHR

pag. 24

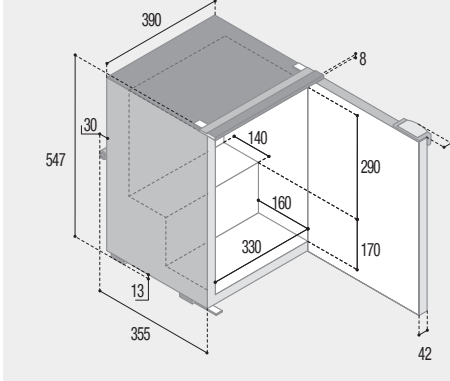

	DOOR	INSIDE	OUTSIDE
MOUNTING FLANGE PROFILO DI FISSAGGIO	t: 25	25	
	w: 453	453	
	h: 584	584	
BUILT-IN VANO INCASSO	a: 393	350	
	b: 405	405	
	c: 548	548	

C42L CHR

pag. 25

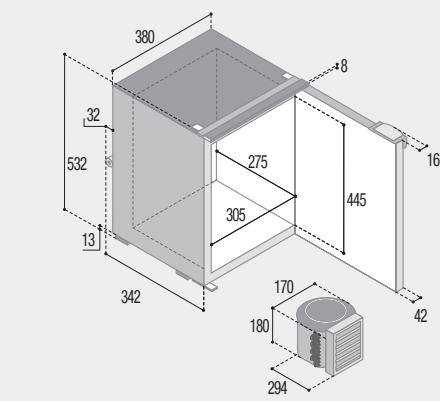

	DOOR	INSIDE	OUTSIDE
MOUNTING FLANGE PROFILO DI FISSAGGIO	t: 25	25	
	w: 443	443	
	h: 569	569	
BUILT-IN VANO INCASSO	a: 379	337	
	b: 395	395	
	c: 533	533	

C42DW CHR

pag. 25

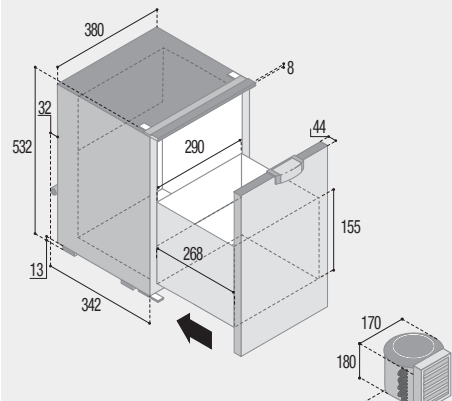

	DOOR	INSIDE	OUTSIDE
MOUNTING FLANGE PROFILO DI FISSAGGIO	t: 25	25	
	w: 443	443	
	h: 569	569	
BUILT-IN VANO INCASSO	a: 379	337	
	b: 395	395	
	c: 533	533	

C25L CHR

pag. 25

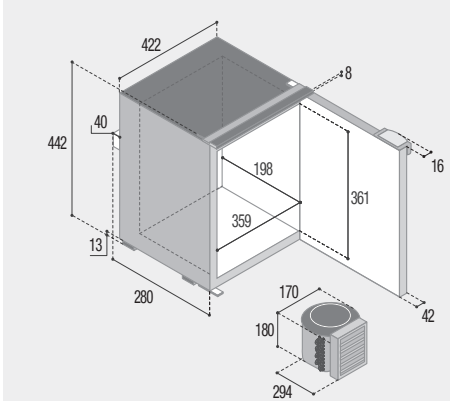

	DOOR	INSIDE	OUTSIDE
MOUNTING FLANGE PROFILO DI FISSAGGIO	t: 25	25	
	w: 484	484	
	h: 454	454	
BUILT-IN VANO INCASSO	a: 322	280	
	b: 439	439	
	c: 433	433	

PORTABLE SERIES
SPECIAL INSTALLATION SERIES

C65L - C65D

pag. 30

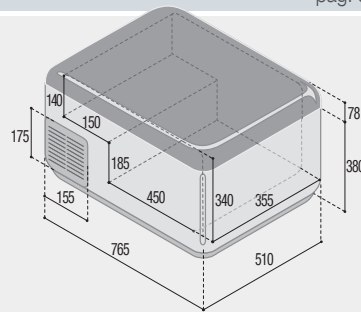

C41L - C41D

pag. 31

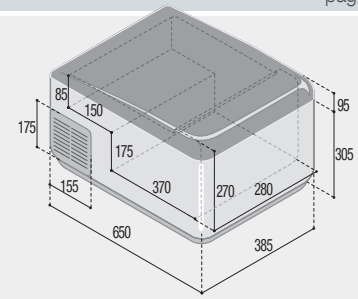

C29M - C29D

pag. 31

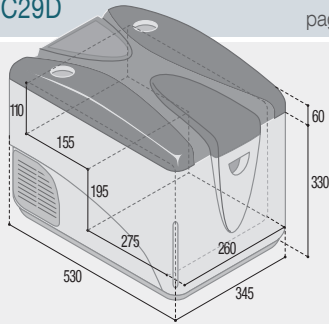

VF65P

pag. 36

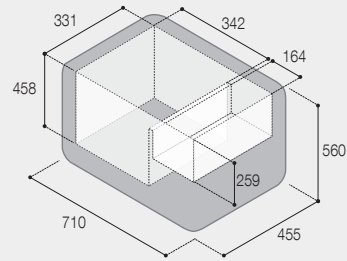

VF55P

pag. 36

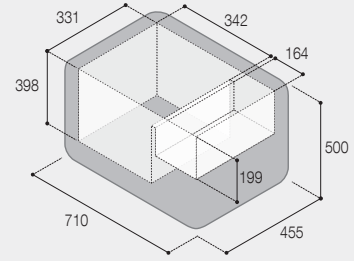

VF45P

pag. 37

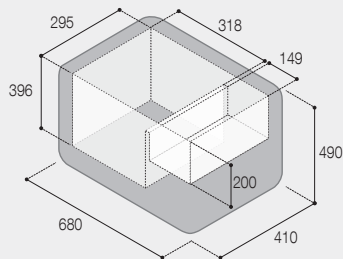

VF35P

pag. 37

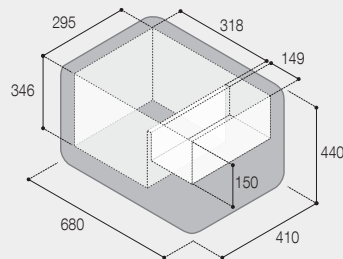

VF16P

pag. 37

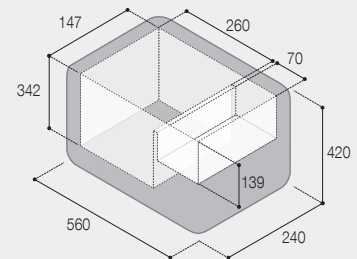

D20A

pag. 43

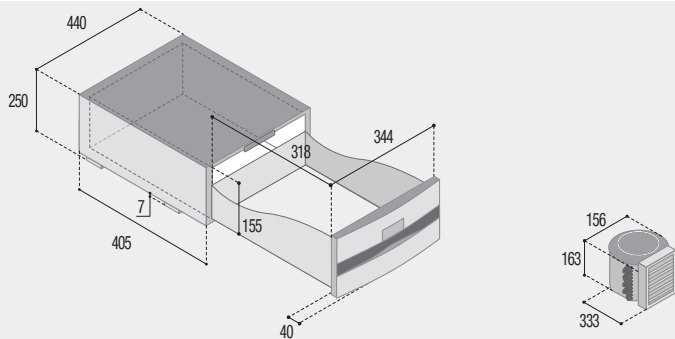

D30A

pag. 43

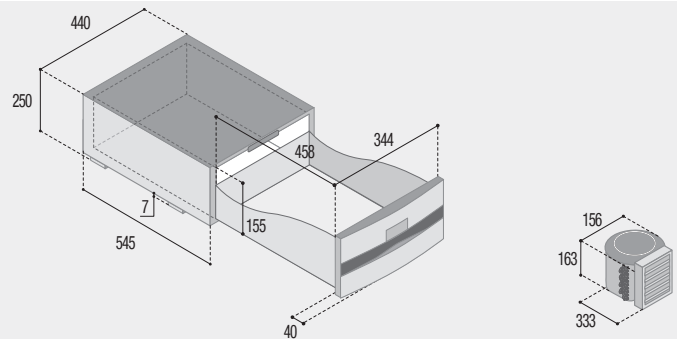

BRK35P

pag. 44

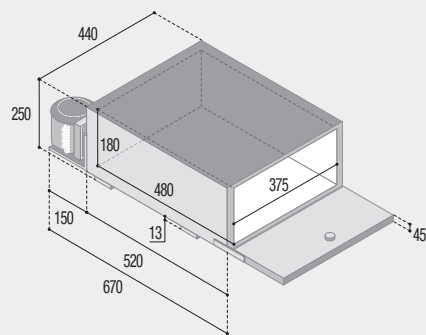

C47 CHR

pag. 45

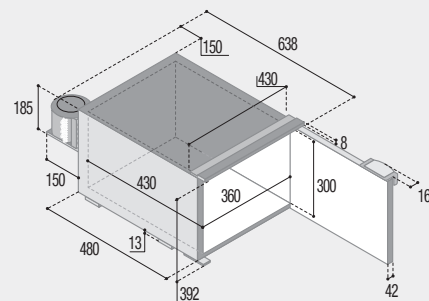

	DOOR	INSIDE	OUTSIDE
MOUNTING FLANGE	t:	25	25
PROFILO DI FISSAGGIO	w:	588	588
	h:	379	379
BUILT-IN	a:	676	633
VANO INCASSO	b:	445	445
	c:	393	393

M25

pag. 46

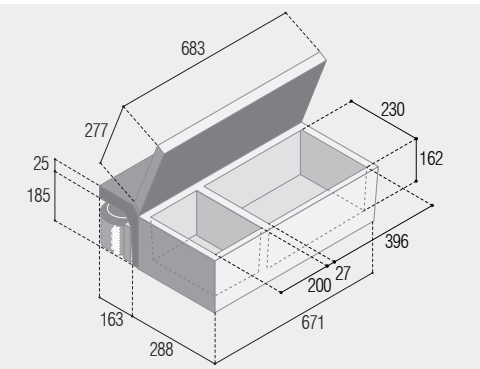

V26

pag. 46

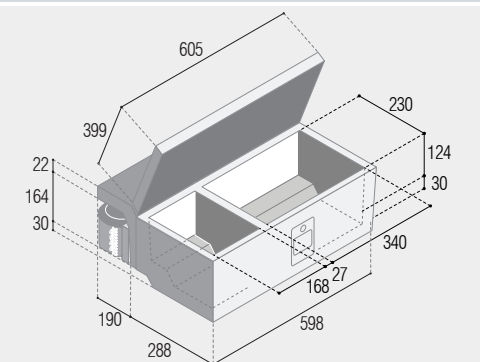

V31

pag. 47

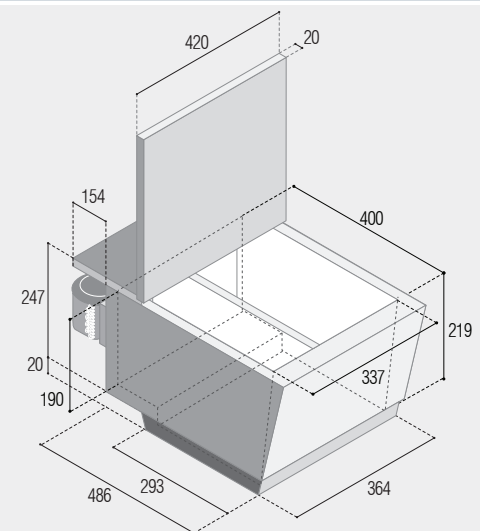

S44

pag. 47

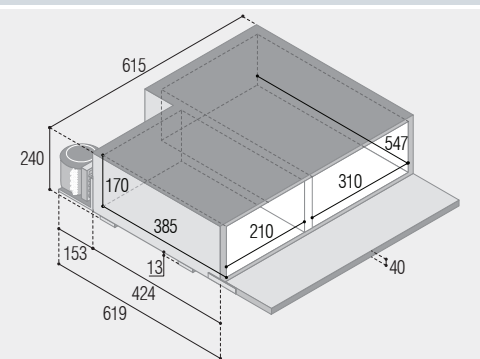

Code chart

Legenda codici

REFRIGERATORS AND FREEZERS WITH BUILT-IN/REMOTE UNIT

- C** fridges and freezers series with front door opening
- I** internal cooling unit version
- L** external cooling unit version
- DW** drawer version

FRIGORIFERI E FREEZER CON UNITA' ESTERNA/INTERNA

- serie frigoriferi e freezer con apertura frontale
- versione con unità refrigerante interna
- versione con unità refrigerante esterna
- versione a cassetto

PORTABLE AND SPECIAL INSTALLATION REFRIGERATORS

- C** fridges and freezers series with front door opening
- L** LED thermostat version
- D** digital thermostat version
- M** mechanical thermostat version
- P** BRK35 version with PUSH-PULL lock

FRIGORIFERI PORTATILI E PER INSTALLAZIONI SPECIALI

- serie frigoriferi e freezer con apertura frontale
- versione con termostato a LED
- versione con termostato digitale
- versione con termostato meccanico
- versione BRK35 con chiusura PUSH-PULL

Vitrifrigo reserves the right to make any changes it deems fit for technical or business purposes at any time and with no prior warning.

Vitrifrigo si riserva il diritto di inserire in qualsiasi momento, e senza obbligo di preavviso, tutte le modifiche considerate opportune per ragioni tecniche o commerciali.

OVERTRUCK

VITRIFRIGO

COOL AND BEYOND



VITRI ALCESTE GROUP

Vitrifrigo S.r.l.
Vallefoglia (PU) - Italy
www.vitrifrigo.com

