

**▷ CATALOGO COMPLETO
COMPLETE CATALOGUE**

RIVACOLD
TRUCK REFRIGERATION

RTR - REFRIGERAZIONE PER CAMION

TRASPORTO

RTR - TRUCK REFRIGERATION TRANSPORTS

RIVACOLD
TRUCK REFRIGERATION

BAT



DDU



YOUR NEW SOLUTION

CARATTERISTICHE GENERALI

- GRUPPI A COMPRESSORE TRAINATO
- SISTEMI COMPLETI CON EVAPORATORE
- CONTROLLO ELETTRONICO REMOTO (POSTO GUIDA)
- SISTEMI CON CONDENSATORE A BORDO
- KIT DI INSTALLAZIONE
- GRUPPI A BATTERIA

GENERAL FEATURES

- DIRECT DRIVEN SYSTEMS
- COMPLETE SYSTEMS WITH EVAPORATORS
- REMOTE CONTROL BOARD (DRIVER CABIN)
- BUILT-IN CONDENSER SYSTEMS
- INSTALLATION KIT
- BATTERY SYSTEMS

GAMMA

BAT006
BAT012
HDD014
HDD022
DDU016
DDU020
DDU025
DDU035
DDU040

MBP

0°C (Tc)

647 Watt
955 Watt
1390 Watt
2160 Watt
1572 Watt
1677 Watt
2347 Watt
3422 Watt
3766 Watt



LBP

-20°C (Tc)

-
429 Watt
-
905 Watt
573 Watt
766 Watt
1213 Watt
1798 Watt
1890 Watt



REFRIGERANTE

R134a
R404A
R134a
R404A
R404A
R404A
R404A
R404A
R404A

Battery Unit BAT006A0Y

SCHEDA DATI TECNICI / TECHNICAL DATASHEET

FUNZIONAMENTO OPERATING MODE		STRADA ROAD																		
REFRIGERANTE REFRIGERANT		R134a																		
Q.TÀ REFRIGERANTE REFRIGERANT CHARGE	kg	0,75																		
CAPACITÀ FRIGORIFERA (TEMP. AMBIENTE +30°C) COOLING CAPACITY (AMBIENT TEMP. +30°C)	W	<table border="0"> <tr> <td>A</td> <td>647</td> <td></td> <td></td> <td>-</td> <td></td> </tr> <tr> <td></td> <td></td> <td></td> <td></td> <td></td> <td></td> </tr> <tr> <td></td> <td></td> <td></td> <td></td> <td></td> <td></td> </tr> </table>	A	647			-													
A	647			-																
MAX VOLUME CELLA CONSIGLIATO (TEMP. AMBIENTE +30°C) MAX SUGGESTED ROOM VOLUME (AMBIENT TEMP. +30°C)	m³	<table border="0"> <tr> <td></td> <td>5</td> <td></td> <td></td> <td></td> <td></td> </tr> <tr> <td></td> <td></td> <td></td> <td></td> <td></td> <td></td> </tr> <tr> <td></td> <td></td> <td></td> <td></td> <td></td> <td></td> </tr> </table>		5																
	5																			
ALIMENTAZIONE ELETTRICA POWER SUPPLY		<table border="0"> <tr> <td>A</td> <td>12 Vdc</td> <td></td> <td></td> <td></td> <td></td> </tr> </table>	A	12 Vdc																
A	12 Vdc																			
ASSORBIMENTO MASSIMO MAXIMUM ABSORPTION		<table border="0"> <tr> <td>A</td> <td>67,6 A</td> <td></td> <td></td> <td></td> <td></td> </tr> </table>	A	67,6 A																
A	67,6 A																			
MOTORE ELETTRICO ELECTRIC MOTOR		40 A																		
SBRINAMENTO DEFROST		ARIA AIR																		
PESO UNITÀ CONDENSANTE CONDENSING UNIT WEIGHT	kg	59																		
PESO UNITÀ EVAPORANTE EVAPORATING UNIT WEIGHT	kg	16																		
COMPRESSORI COMPRESSORS		<table border="0"> <tr> <td>A</td> <td>Dorin 45cc</td> <td></td> <td></td> <td></td> <td></td> </tr> </table>	A	Dorin 45cc																
A	Dorin 45cc																			
PORTATA ARIA VENTILATORI EVAPORATORE EVAPORATING UNIT FAN AIR FLOW	m³/h	640																		
FRECCIA ARIA VENTILATORI EVAPORATORE EVAPORATING UNIT FAN AIR THROW	m	2,5																		

DIMENSIONI / SIZES

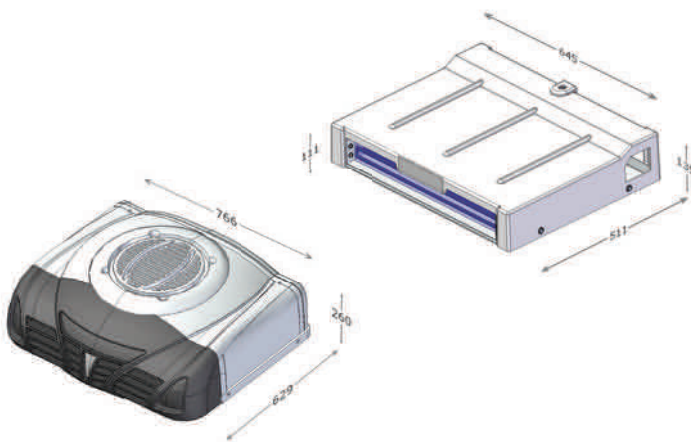

IMBALLO / PACKING

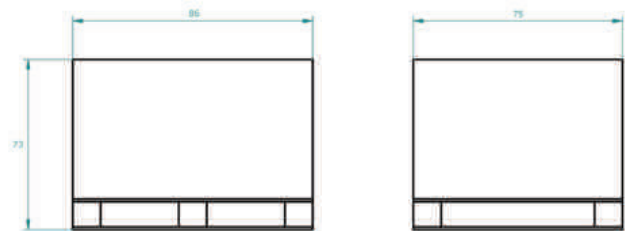

DOTAZIONE DI SERIE / STANDARD EQUIPMENT

- Unità condensatrice predisposta per montaggio a soffitto (in opzione montaggio a sbalzo) / Condensing Unit suitable for rooftop mounting (optional nose mounting)
- Unità evaporante predisposta per montaggio a soffitto (accessori per il fissaggio inclusi) / Evaporating Unit suitable for rooftop mounting (accessories included)
- Kit accessori scarico condensa / Water drain accessories
- Kit accessori (tubazioni e raccordi) per il collegamento frigorifero / Refrigeration connection kit (hoses and fittings)
- Kit accessori per il collegamento elettrico (cavi batteria) / Electrical connection kit (Vehicle battery power cables)
- Comando cabina / Cab Controller

NOTE / NOTES

















FUNZIONAMENTO "STRADA"
"ROAD" OPERATION



FUNZIONAMENTO "RETE"
"STAND-BY" OPERATION

Battery Unit BAT006A1Y

SCHEDA DATI TECNICI / TECHNICAL DATASHEET

FUNZIONAMENTO OPERATING MODE		STRADA + RETE ROAD + STANDBY	
REFRIGERANTE REFRIGERANT		R134a	
Q.TÀ REFRIGERANTE REFRIGERANT CHARGE	kg	0,75	
CAPACITÀ FRIGORIFERA (TEMP. AMBIENTE +30°C) COOLING CAPACITY (AMBIENT TEMP. +30°C)	W	647   	667   
MAX VOLUME CELLA CONSIGLIATO (TEMP. AMBIENTE +30°C) MAX SUGGESTED ROOM VOLUME (AMBIENT TEMP. +30°C)	m ³	5 	- 
ALIMENTAZIONE ELETTRICA POWER SUPPLY		12 Vdc 	230 Vac / 50 Hz 
ASSORBIMENTO MASSIMO MAXIMUM ABSORPTION		67,6 A 	6,6 A 
MOTORE ELETTRICO ELECTRIC MOTOR		40 A	
SBRINAMENTO DEFROST		ARIA AIR	
PESO UNITÀ CONDENSANTE CONDENSING UNIT WEIGHT	kg	79	
PESO UNITÀ EVAPORANTE EVAPORATING UNIT WEIGHT	kg	16	
COMPRESSORI COMPRESSORS		Dorin 45cc 	- 
PORTATA ARIA VENTILATORI EVAPORATORE EVAPORATING UNIT FAN AIR FLOW	m ³ /h	640	
FRECCIA ARIA VENTILATORI EVAPORATORE EVAPORATING UNIT FAN AIR THROW	m	2,5	

DIMENSIONI / SIZES

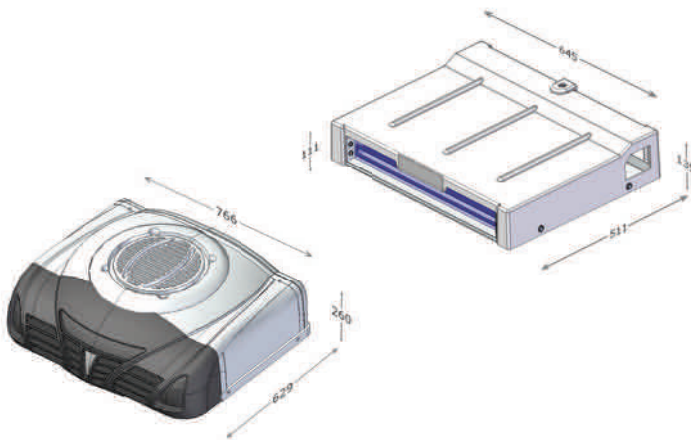

IMBALLO / PACKING

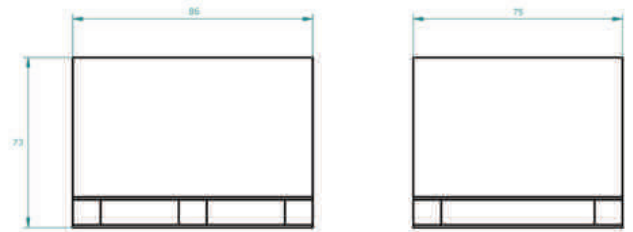

DOTAZIONE DI SERIE / STANDARD EQUIPMENT

- Unità condensatrice predisposta per montaggio a soffitto (in opzione montaggio a sbalzo) / Condensing Unit suitable for rooftop mounting (optional nose mounting)
- Unità evaporante predisposta per montaggio a soffitto (accessori per il fissaggio inclusi) / Evaporating Unit suitable for rooftop mounting (accessories included)
- Kit accessori scarico condensa / Water drain accessories
- Kit accessori (tubazioni e raccordi) per il collegamento frigorifero / Refrigeration connection kit (hoses and fittings)
- Kit accessori per il collegamento elettrico (cavi batteria) / Electrical connection kit (Vehicle battery power cables)
- Comando cabina / Cab Controller

NOTE / NOTES

















FUNZIONAMENTO "STRADA"
"ROAD" OPERATION



FUNZIONAMENTO "RETE"
"STAND-BY" OPERATION

Battery Unit BAT012A0Z

SCHEDA DATI TECNICI / TECHNICAL DATASHEET

FUNZIONAMENTO OPERATING MODE		STRADA ROAD	
REFRIGERANTE REFRIGERANT		R404A	
Q.TÀ REFRIGERANTE REFRIGERANT CHARGE	kg	0,63	
CAPACITÀ FRIGORIFERA (TEMP. AMBIENTE +30°C) COOLING CAPACITY (AMBIENT TEMP. +30°C)	W	 955  429 	 -   - 
MAX VOLUME CELLA CONSIGLIATO (TEMP. AMBIENTE +30°C) MAX SUGGESTED ROOM VOLUME (AMBIENT TEMP. +30°C)	m ³	8 	5 
ALIMENTAZIONE ELETTRICA POWER SUPPLY		 12 Vdc	 -
ASSORBIMENTO MASSIMO MAXIMUM ABSORPTION		 92,6 A	 -
MOTORE ELETTRICO ELECTRIC MOTOR		65 A	
SBRINAMENTO DEFROST		GAS CALDO HOT GAS	
PESO UNITÀ CONDENSANTE CONDENSING UNIT WEIGHT	kg	65	
PESO UNITÀ EVAPORANTE EVAPORATING UNIT WEIGHT	kg	18	
COMPRESSORI COMPRESSORS		 Dorin 45cc	 -
PORTATA ARIA VENTILATORI EVAPORATORE EVAPORATING UNIT FAN AIR FLOW	m ³ /h	640	
FRECCIA ARIA VENTILATORI EVAPORATORE EVAPORATING UNIT FAN AIR THROW	m	2,5	

DIMENSIONI / SIZES

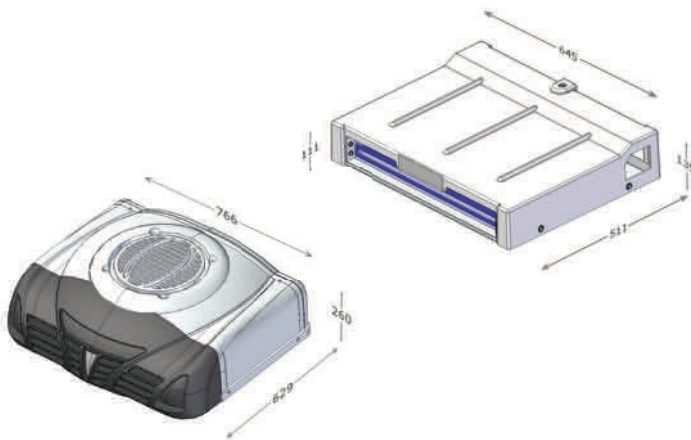

IMBALLO / PACKING

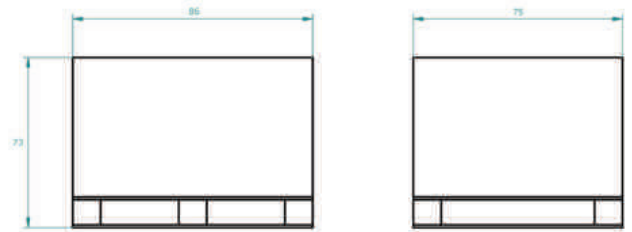

DOTAZIONE DI SERIE / STANDARD EQUIPMENT

- Unità condensatrice predisposta per montaggio a soffitto (in opzione montaggio a sbalzo) / Condensing Unit suitable for rooftop mounting (optional nose mounting)
- Unità evaporante predisposta per montaggio a soffitto (accessori per il fissaggio inclusi) / Evaporating Unit suitable for rooftop mounting (accessories included)
- Kit accessori scarico condensa / Water drain accessories
- Kit accessori (tubazioni e raccordi) per il collegamento frigorifero / Refrigeration connection kit (hoses and fittings)
- Kit accessori per il collegamento elettrico (cavi batteria) / Electrical connection kit (Vehicle battery power cables)
- Comando cabina / Cab Controller

NOTE / NOTES















FUNZIONAMENTO "STRADA"
"ROAD" OPERATION



FUNZIONAMENTO "RETE"
"STAND-BY" OPERATION

Battery Unit BAT012A1Z

SCHEDA DATI TECNICI / TECHNICAL DATASHEET

FUNZIONAMENTO OPERATING MODE		STRADA + RETE ROAD + STANDBY	
REFRIGERANTE REFRIGERANT		R404A	
Q.TÀ REFRIGERANTE REFRIGERANT CHARGE	kg	0,63	
CAPACITÀ FRIGORIFERA (TEMP. AMBIENTE +30°C) COOLING CAPACITY (AMBIENT TEMP. +30°C)	W	955  429 	1050  704 
MAX VOLUME CELLA CONSIGLIATO (TEMP. AMBIENTE +30°C) MAX SUGGESTED ROOM VOLUME (AMBIENT TEMP. +30°C)	m ³	8  5 	
ALIMENTAZIONE ELETTRICA POWER SUPPLY		 12 Vdc	 230 Vac / 50 Hz
ASSORBIMENTO MASSIMO MAXIMUM ABSORPTION		 92,6 A	 6,6 A
MOTORE ELETTRICO ELECTRIC MOTOR		65 A	
SBRINAMENTO DEFROST		GAS CALDO HOT GAS	
PESO UNITÀ CONDENSANTE CONDENSING UNIT WEIGHT	kg	85	
PESO UNITÀ EVAPORANTE EVAPORATING UNIT WEIGHT	kg	18	
COMPRESSORI COMPRESSORS		 Dorin 45cc	 -
PORTATA ARIA VENTILATORI EVAPORATORE EVAPORATING UNIT FAN AIR FLOW	m ³ /h	640	
FRECCIA ARIA VENTILATORI EVAPORATORE EVAPORATING UNIT FAN AIR THROW	m	2,5	

DIMENSIONI / SIZES

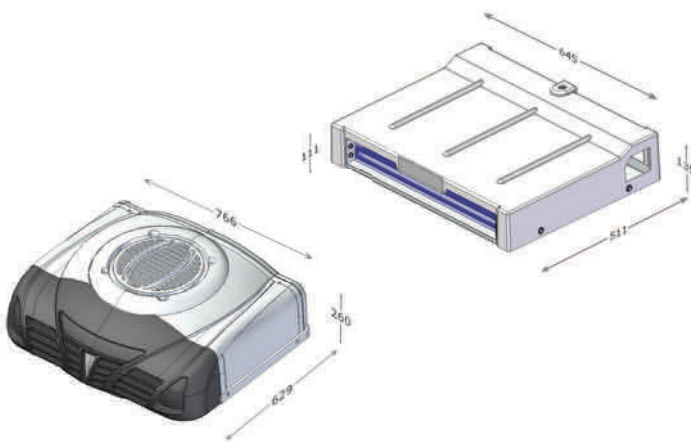

IMBALLO / PACKING

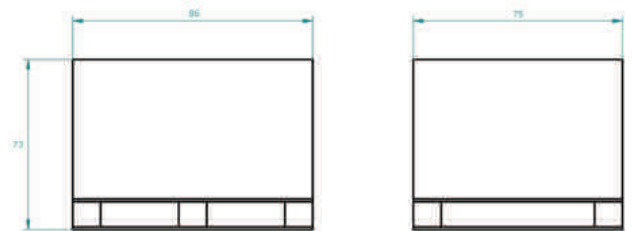

DOTAZIONE DI SERIE / STANDARD EQUIPMENT

- Unità condensatrice predisposta per montaggio a soffitto (in opzione montaggio a sbalzo) / Condensing Unit suitable for rooftop mounting (optional nose mounting)
- Unità evaporante predisposta per montaggio a soffitto (accessori per il fissaggio inclusi) / Evaporating Unit suitable for rooftop mounting (accessories included)
- Kit accessori scarico condensa / Water drain accessories
- Kit accessori (tubazioni e raccordi) per il collegamento frigorifero / Refrigeration connection kit (hoses and fittings)
- Kit accessori per il collegamento elettrico (cavi batteria) / Electrical connection kit (Vehicle battery power cables)
- Comando cabina / Cab Controller

NOTE / NOTES



FUNZIONAMENTO "STRADA"
"ROAD" OPERATION



FUNZIONAMENTO "RETE"
"STAND-BY" OPERATION

Hidden Direct Drive HDD014MCRY10

SCHEDA DATI TECNICI / TECHNICAL DATASHEET

FUNZIONAMENTO OPERATING MODE		STRADA ROAD												
REFRIGERANTE REFRIGERANT		R134a												
Q.TÀ REFRIGERANTE REFRIGERANT CHARGE	kg	1,1												
CAPACITÀ FRIGORIFERA (TEMP. AMBIENTE +30°C) COOLING CAPACITY (AMBIENT TEMP. +30°C)	W	<table border="0"> <tr> <td>A</td> <td>1390</td> <td></td> <td></td> <td>-</td> <td></td> </tr> <tr> <td></td> <td></td> <td></td> <td></td> <td>-</td> <td></td> </tr> </table>	A	1390			-						-	
A	1390			-										
				-										
MAX VOLUME CELLA CONSIGLIATO (TEMP. AMBIENTE +30°C) MAX SUGGESTED ROOM VOLUME (AMBIENT TEMP. +30°C)	m³	<table border="0"> <tr> <td></td> <td>5</td> <td></td> <td></td> <td></td> <td></td> </tr> <tr> <td></td> <td>-</td> <td></td> <td></td> <td></td> <td></td> </tr> </table>		5						-				
	5													
	-													
ALIMENTAZIONE ELETTRICA POWER SUPPLY		A 12 Vdc -												
ASSORBIMENTO MASSIMO MAXIMUM ABSORPTION		A 18,1 A -												
MOTORE ELETTRICO ELECTRIC MOTOR		-												
SBRINAMENTO DEFROST		ARIA AIR												
PESO UNITÀ CONDENSANTE CONDENSING UNIT WEIGHT	kg	3												
PESO UNITÀ EVAPORANTE EVAPORATING UNIT WEIGHT	kg	15												
COMPRESSORI COMPRESSORS		A SANDEN SD5H09 -												
PORTATA ARIA VENTILATORI EVAPORATORE EVAPORATING UNIT FAN AIR FLOW	m³/h	910												
FRECCIA ARIA VENTILATORI EVAPORATORE EVAPORATING UNIT FAN AIR THROW	m	3,5												

DIMENSIONI / SIZES

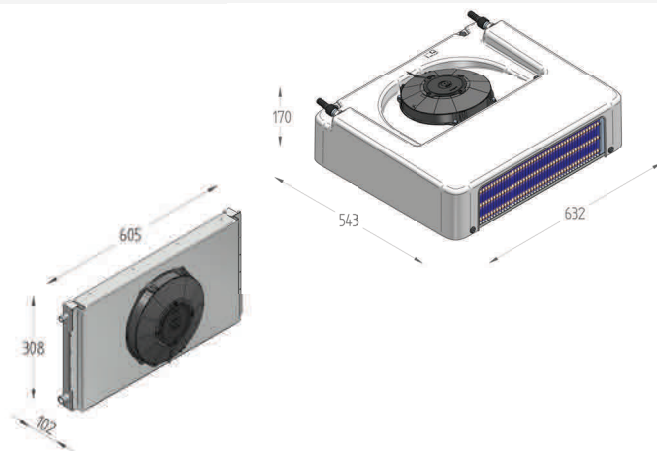

IMBALLO / PACKING



DOTAZIONE DI SERIE / STANDARD EQUIPMENT

- Unità condensatrice predisposta per montaggio frontale o sottotelaio (accessori per il fissaggio inclusi) / Condensing Unit suitable for front or undermount (accessories included)
- Unità evaporante predisposta per montaggio a soffitto (accessori per il fissaggio inclusi) / Evaporating Unit suitable for rooftop mounting (accessories included)
- Kit accessori scarico condensa / Water drain accessories
- Kit accessori (tubazioni e raccordi) per il collegamento frigorifero / Refrigeration connection kit (hoses and fittings)
- Kit accessori per il collegamento elettrico (cavi batteria) / Electrical connection kit (Vehicle battery power cables)
- Comando cabina / Cab Controller

NOTE / NOTES

- Il compressore "Strada" indicato è quello con cui è stata omologata l'unità, ma non è parte della dotazione standard
The "Road" compressor is the one used for the APT certification of the unit, but it's not in the standard equipment
- Il kit di staffaggio del compressore strada nel veicolo non è parte della dotazione standard
The "Road" compressor mounting kit is not in the standard equipment



FUNZIONAMENTO "STRADA"
"ROAD" OPERATION





















FUNZIONAMENTO "RETE"
"STAND-BY" OPERATION

Hidden Direct Drive HDD014MCSY11

RIVACOLD
TRUCK REFRIGERATION

SCHEDA DATI TECNICI / TECHNICAL DATASHEET

FUNZIONAMENTO OPERATING MODE		STRADA + RETE ROAD + STANDBY	
REFRIGERANTE REFRIGERANT		R134a	
Q.TÀ REFRIGERANTE REFRIGERANT CHARGE	kg	1,1	
CAPACITÀ FRIGORIFERA (TEMP. AMBIENTE +30°C) COOLING CAPACITY (AMBIENT TEMP. +30°C)	W	1390   -  	690   -  
MAX VOLUME CELLA CONSIGLIATO (TEMP. AMBIENTE +30°C) MAX SUGGESTED ROOM VOLUME (AMBIENT TEMP. +30°C)	m³	5   -  	
ALIMENTAZIONE ELETTRICA POWER SUPPLY		12 Vdc 	 230 V / 1 ph / 50 Hz
ASSORBIMENTO MASSIMO MAXIMUM ABSORPTION		18,1 A 	 18,4 A
MOTORE ELETTRICO ELECTRIC MOTOR		-	
SBRINAMENTO DEFROST		GAS CALDO HOT GAS	
PESO UNITÀ CONDENSANTE CONDENSING UNIT WEIGHT	kg	3	
PESO UNITÀ EVAPORANTE EVAPORATING UNIT WEIGHT	kg	15	
COMPRESSORI COMPRESSORS		 SANDEN SD5H09	 TECUMSEH HGA4476Y
PORTATA ARIA VENTILATORI EVAPORATORE EVAPORATING UNIT FAN AIR FLOW	m³/h	910	
FRECCIA ARIA VENTILATORI EVAPORATORE EVAPORATING UNIT FAN AIR THROW	m	3,5	

DIMENSIONI / SIZES

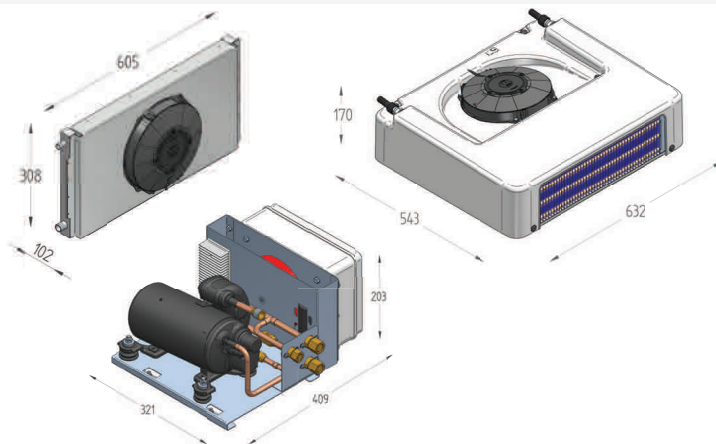

IMBALLO / PACKING

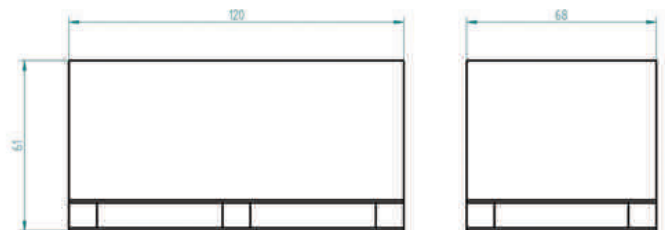

DOTAZIONE DI SERIE / STANDARD EQUIPMENT

- Unità condensatrice predisposta per montaggio frontale o sottotelaio (accessori per il fissaggio inclusi) / Condensing Unit suitable for front or undermount (accessories included)
- Unità evaporante predisposta per montaggio a soffitto (accessori per il fissaggio inclusi) / Evaporating Unit suitable for rooftop mounting (accessories included)
- Kit accessori scarico condensa / Water drain accessories
- Kit accessori (tubazioni e raccordi) per il collegamento frigorifero / Refrigeration connection kit (hoses and fittings)
- Kit accessori per il collegamento elettrico (cavi batteria) / Electrical connection kit (Vehicle battery power cables)
- Comando cabina / Cab Controller

NOTE / NOTES

- Il compressore "Strada" indicato è quello con cui è stata omologata l'unità, ma non è parte della dotazione standard
The "Road" compressor is the one used for the APT certification of the unit, but it's not in the standard equipment
- Il kit di staffaggio del compressore strada nel veicolo non è parte della dotazione standard
The "Road" compressor mounting kit is not in the standard equipment























FUNZIONAMENTO "STRADA"
"ROAD" OPERATION



FUNZIONAMENTO "RETE"
"STAND-BY" OPERATION

Hidden Direct Drive HDD022MCRZ10

SCHEDA DATI TECNICI / TECHNICAL DATASHEET

FUNZIONAMENTO OPERATING MODE		STRADA ROAD	
REFRIGERANTE REFRIGERANT		R404A	
Q.TÀ REFRIGERANTE REFRIGERANT CHARGE	kg	1,3	
CAPACITÀ FRIGORIFERA (TEMP. AMBIENTE +30°C) COOLING CAPACITY (AMBIENT TEMP. +30°C)	W	 2160   905  	 -    -  
MAX VOLUME CELLA CONSIGLIATO (TEMP. AMBIENTE +30°C) MAX SUGGESTED ROOM VOLUME (AMBIENT TEMP. +30°C)	m ³	15   10  	
ALIMENTAZIONE ELETTRICA POWER SUPPLY		 12 Vdc	 -
ASSORBIMENTO MASSIMO MAXIMUM ABSORPTION		 30 A	 -
MOTORE ELETTRICO ELECTRIC MOTOR		-	
SBRINAMENTO DEFROST		GAS CALDO HOT GAS	
PESO UNITÀ CONDENSANTE CONDENSING UNIT WEIGHT	kg	5	
PESO UNITÀ EVAPORANTE EVAPORATING UNIT WEIGHT	kg	18	
COMPRESSORI COMPRESSORS		 SELTEC TM15	 -
PORTATA ARIA VENTILATORI EVAPORATORE EVAPORATING UNIT FAN AIR FLOW	m ³ /h	1220	
FRECCIA ARIA VENTILATORI EVAPORATORE EVAPORATING UNIT FAN AIR THROW	m	3,5	

DIMENSIONI / SIZES

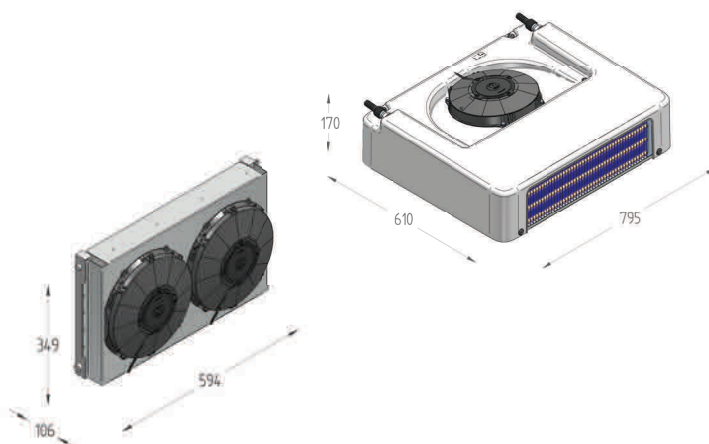

IMBALLO / PACKING

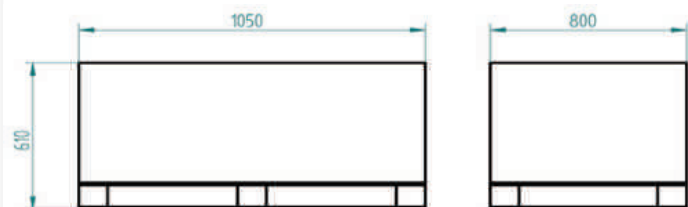

DOTAZIONE DI SERIE / STANDARD EQUIPMENT

- Unità condensatrice predisposta per montaggio frontale o sottotelaio (accessori per il fissaggio inclusi) / Condensing Unit suitable for front or undermount (accessories included)
- Unità evaporante predisposta per montaggio a soffitto (accessori per il fissaggio inclusi) / Evaporating Unit suitable for rooftop mounting (accessories included)
- Kit accessori scarico condensa / Water drain accessories
- Kit accessori (tubazioni e raccordi) per il collegamento frigorifero / Refrigeration connection kit (hoses and fittings)
- Kit accessori per il collegamento elettrico (cavi batteria) / Electrical connection kit (Vehicle battery power cables)
- Comando cabina / Cab Controller

NOTE / NOTES

- Il compressore "Strada" indicato è quello con cui è stata omologata l'unità, ma non è parte della dotazione standard
The "Road" compressor is the one used for the APT certification of the unit, but it's not in the standard equipment
- Il kit di staffaggio del compressore strada nel veicolo non è parte della dotazione standard
The "Road" compressor mounting kit is not in the standard equipment



















FUNZIONAMENTO "STRADA"
"ROAD" OPERATION



FUNZIONAMENTO "RETE"
"STAND-BY" OPERATION

Hidden Direct Drive HDD022MCSZ11

SCHEDA DATI TECNICI / TECHNICAL DATASHEET

FUNZIONAMENTO OPERATING MODE		STRADA + RETE ROAD + STANDBY	
REFRIGERANTE REFRIGERANT		R404A	
Q.TÀ REFRIGERANTE REFRIGERANT CHARGE	kg	1,3	
CAPACITÀ FRIGORIFERA (TEMP. AMBIENTE +30°C) COOLING CAPACITY (AMBIENT TEMP. +30°C)	W	2160  	 
		905  	 
MAX VOLUME CELLA CONSIGLIATO (TEMP. AMBIENTE +30°C) MAX SUGGESTED ROOM VOLUME (AMBIENT TEMP. +30°C)	m³	15  	
		10  	
ALIMENTAZIONE ELETTRICA POWER SUPPLY		12 Vdc	 230 V / 1 ph / 50 Hz
ASSORBIMENTO MASSIMO MAXIMUM ABSORPTION		30 A	 30,2 A
MOTORE ELETTRICO ELECTRIC MOTOR		-	
SBRINAMENTO DEFROST		GAS CALDO HOT GAS	
PESO UNITÀ CONDENSANTE CONDENSING UNIT WEIGHT	kg	5	
PESO UNITÀ EVAPORANTE EVAPORATING UNIT WEIGHT	kg	18	
COMPRESSORI COMPRESSORS		 SELTEC TM15	 BOYARD QHD-30K
PORTATA ARIA VENTILATORI EVAPORATORE EVAPORATING UNIT FAN AIR FLOW	m³/h	1220	
FRECCIA ARIA VENTILATORI EVAPORATORE EVAPORATING UNIT FAN AIR THROW	m	3,5	

DIMENSIONI / SIZES

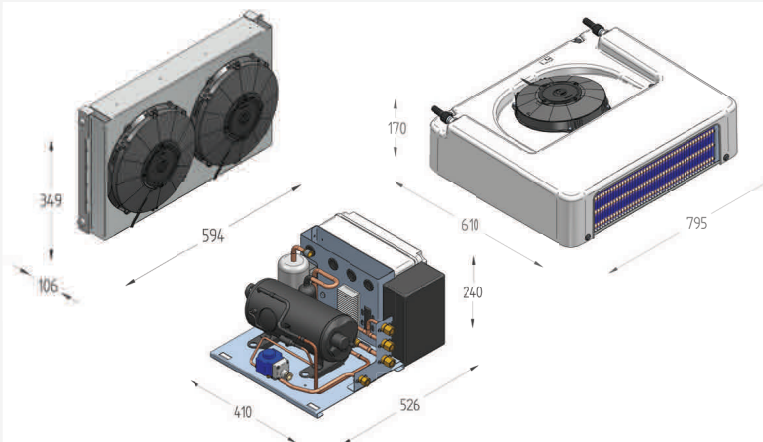

IMBALLO / PACKING

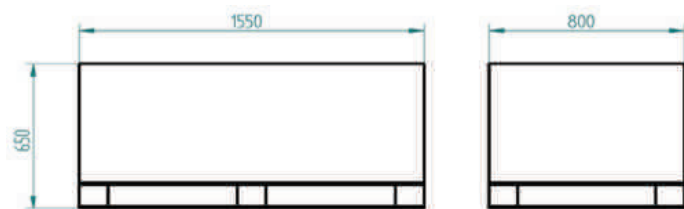

DOTAZIONE DI SERIE / STANDARD EQUIPMENT

- Unità condensatrice predisposta per montaggio frontale o sottotelaio (accessori per il fissaggio inclusi) / Condensing Unit suitable for front or undermount (accessories included)
- Unità evaporante predisposta per montaggio a soffitto (accessori per il fissaggio inclusi) / Evaporating Unit suitable for rooftop mounting (accessories included)
- Kit accessori scarico condensa / Water drain accessories
- Kit accessori (tubazioni e raccordi) per il collegamento frigorifero / Refrigeration connection kit (hoses and fittings)
- Kit accessori per il collegamento elettrico (cavi batteria) / Electrical connection kit (Vehicle battery power cables)
- Comando cabina / Cab Controller

NOTE / NOTES

- Il compressore "Strada" indicato è quello con cui è stata omologata l'unità, ma non è parte della dotazione standard / The "Road" compressor is the one used for the APT certification of the unit, but it's not in the standard equipment
- Il kit di staffaggio del compressore strada nel veicolo non è parte della dotazione standard / The "Road" compressor mounting kit is not in the standard equipment



FUNZIONAMENTO "STRADA"
"ROAD" OPERATION



FUNZIONAMENTO "RETE"
"STAND-BY" OPERATION

Direct Drive Unit















DDU016MCRZ10

ETR016Z11

RIVACOLD

TRUCK REFRIGERATION

SCHEDA DATI TECNICI / TECHNICAL DATASHEET

FUNZIONAMENTO OPERATING MODE		STRADA ROAD	
REFRIGERANTE REFRIGERANT		R404A	
Q.TÀ REFRIGERANTE REFRIGERANT CHARGE	kg	0,9	
CAPACITÀ FRIGORIFERA (TEMP. AMBIENTE +30°C) COOLING CAPACITY (AMBIENT TEMP. +30°C)	W	 1572 	 - 
		573 	 - 
MAX VOLUME CELLA CONSIGLIATO (TEMP. AMBIENTE +30°C) MAX SUGGESTED ROOM VOLUME (AMBIENT TEMP. +30°C)	m ³	10 	
		5 	
ALIMENTAZIONE ELETTRICA POWER SUPPLY		 12 Vdc	 -
ASSORBIMENTO MASSIMO MAXIMUM ABSORPTION		 22,4 A	 -
MOTORE ELETTRICO ELECTRIC MOTOR		-	
SBRINAMENTO DEFROST		GAS CALDO HOT GAS	
PESO UNITÀ CONDENSANTE CONDENSING UNIT WEIGHT	kg	35	
PESO UNITÀ EVAPORANTE EVAPORATING UNIT WEIGHT	kg	10	
COMPRESSORI COMPRESSORS		 SELTEC TM13	 -
PORTATA ARIA VENTILATORI EVAPORATORE EVAPORATING UNIT FAN AIR FLOW	m ³ /h	910	
FRECCIA ARIA VENTILATORI EVAPORATORE EVAPORATING UNIT FAN AIR THROW	m	3	

DIMENSIONI / SIZES

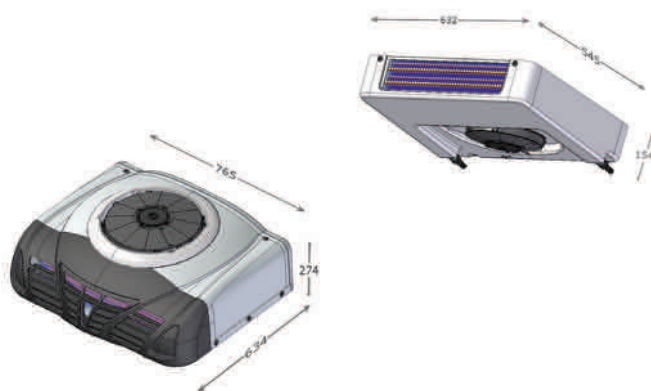

IMBALLO / PACKING

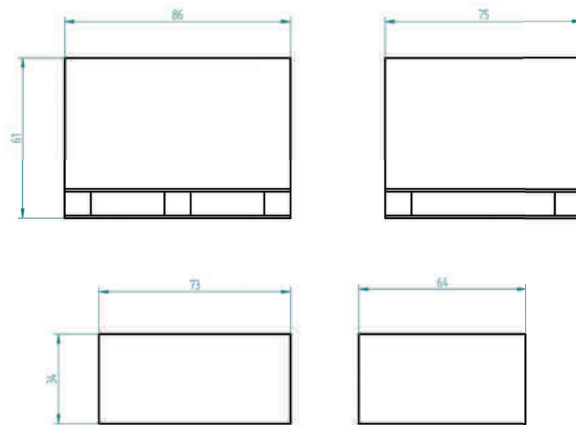

DOTAZIONE DI SERIE / STANDARD EQUIPMENT

- Unità condensatrice predisposta per montaggio a soffitto (in opzione montaggio a sbalzo) / Condensing Unit suitable for rooftop mounting (optional nose mounting)
- Unità evaporante predisposta per montaggio a soffitto (accessori per il fissaggio inclusi) / Evaporating Unit suitable for rooftop mounting (accessories included)
- Kit accessori scarico condensa / Water drain accessories
- Kit accessori (tubazioni e raccordi) per il collegamento frigorifero / Refrigeration connection kit (hoses and fittings)
- Kit accessori per il collegamento elettrico (cavi batteria) / Electrical connection kit (Vehicle battery power cables)
- Comando cabina / Cab Controller

NOTE / NOTES

- Il compressore "Strada" indicato è quello con cui è stata omologata l'unità, ma non è parte della dotazione standard
The "Road" compressor is the one used for the APT certification of the unit, but it's not in the standard equipment
- Il kit di staffaggio del compressore strada nel veicolo non è parte della dotazione standard
The "Road" compressor mounting kit is not in the standard equipment



FUNZIONAMENTO "STRADA"
"ROAD" OPERATION



FUNZIONAMENTO "RETE"
"STAND-BY" OPERATION

Direct Drive Unit















DDU016MCSZ11

ETR016Z11

RIVACOLD

TRUCK REFRIGERATION

SCHEDA DATI TECNICI / TECHNICAL DATASHEET

FUNZIONAMENTO OPERATING MODE		STRADA + RETE ROAD + STANDBY	
REFRIGERANTE REFRIGERANT		R404A	
Q.TÀ REFRIGERANTE REFRIGERANT CHARGE	kg	0,9	
CAPACITÀ FRIGORIFERA (TEMP. AMBIENTE +30°C) COOLING CAPACITY (AMBIENT TEMP. +30°C)	W	 1572  573 	 1047  256 
MAX VOLUME CELLA CONSIGLIATO (TEMP. AMBIENTE +30°C) MAX SUGGESTED ROOM VOLUME (AMBIENT TEMP. +30°C)	m³	10  5 	
ALIMENTAZIONE ELETTRICA POWER SUPPLY		 12 Vdc	 230 V / 1 ph / 50 Hz
ASSORBIMENTO MASSIMO MAXIMUM ABSORPTION		 22,4 A	 4,9 A / 1,25 kW
MOTORE ELETTRICO ELECTRIC MOTOR		-	
SBRINAMENTO DEFROST		GAS CALDO HOT GAS	
PESO UNITÀ CONDENSANTE CONDENSING UNIT WEIGHT	kg	60	
PESO UNITÀ EVAPORANTE EVAPORATING UNIT WEIGHT	kg	10	
COMPRESSORI COMPRESSORS		 SELTEC TM13	 TECUMSEH HGA2446Z
PORTATA ARIA VENTILATORI EVAPORATORE EVAPORATING UNIT FAN AIR FLOW	m³/h	910	
FRECCIA ARIA VENTILATORI EVAPORATORE EVAPORATING UNIT FAN AIR THROW	m	3	

DIMENSIONI / SIZES

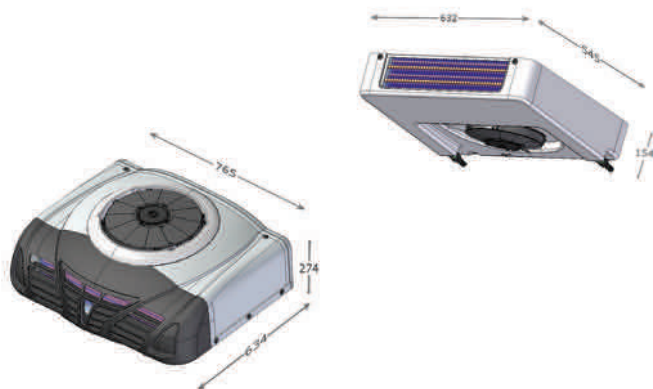

IMBALLO / PACKING

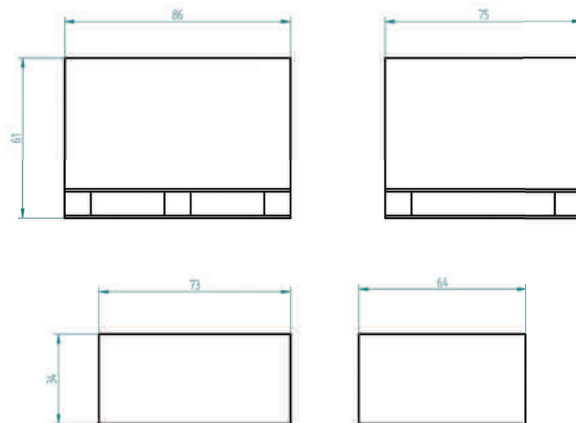

DOTAZIONE DI SERIE / STANDARD EQUIPMENT

- Unità condensatrice predisposta per montaggio a soffitto (in opzione montaggio a sbalzo) / Condensing Unit suitable for rooftop mounting (optional nose mounting)
- Unità evaporante predisposta per montaggio a soffitto (accessori per il fissaggio inclusi) / Evaporating Unit suitable for rooftop mounting (accessories included)
- Kit accessori scarico condensa / Water drain accessories
- Kit accessori (tubazioni e raccordi) per il collegamento frigorifero / Refrigeration connection kit (hoses and fittings)
- Kit accessori per il collegamento elettrico (cavi batteria, cavi e spine alimentazione rete) / Electrical connection kit (Vehicle battery power cables, Stand-by power cables and plugs)
- Comando cabina / Cab Controller

NOTE / NOTES

- Il compressore "Strada" indicato è quello con cui è stata omologata l'unità, ma non è parte della dotazione standard
The "Road" compressor is the one used for the APT certification of the unit, but it's not in the standard equipment
- Il kit di staffaggio del compressore strada nel veicolo non è parte della dotazione standard
The "Road" compressor mounting kit is not in the standard equipment



FUNZIONAMENTO "STRADA"
"ROAD" OPERATION



FUNZIONAMENTO "RETE"
"STAND-BY" OPERATION

Direct Drive Unit DDU020MCRZ10 ETR020Z11

RIVACOLD

TRUCK REFRIGERATION

SCHEDA DATI TECNICI / TECHNICAL DATASHEET

FUNZIONAMENTO OPERATING MODE		STRADA ROAD								
REFRIGERANTE REFRIGERANT		R404A								
Q.TÀ REFRIGERANTE REFRIGERANT CHARGE	kg	1,2								
CAPACITÀ FRIGORIFERA (TEMP. AMBIENTE +30°C) COOLING CAPACITY (AMBIENT TEMP. +30°C)	W	<table border="0"> <tr> <td>1677</td> <td></td> <td>-</td> <td></td> </tr> <tr> <td>766</td> <td></td> <td>-</td> <td></td> </tr> </table>	1677		-		766		-	
1677		-								
766		-								
MAX VOLUME CELLA CONSIGLIATO (TEMP. AMBIENTE +30°C) MAX SUGGESTED ROOM VOLUME (AMBIENT TEMP. +30°C)	m ³	<table border="0"> <tr> <td>11</td> <td></td> </tr> <tr> <td>7</td> <td></td> </tr> </table>	11		7					
11										
7										
ALIMENTAZIONE ELETTRICA POWER SUPPLY		12 Vdc								
ASSORBIMENTO MASSIMO MAXIMUM ABSORPTION		21,2 A								
MOTORE ELETTRICO ELECTRIC MOTOR		-								
SBRINAMENTO DEFROST		GAS CALDO HOT GAS								
PESO UNITÀ CONDENSANTE CONDENSING UNIT WEIGHT	kg	35								
PESO UNITÀ EVAPORANTE EVAPORATING UNIT WEIGHT	kg	11								
COMPRESSORI COMPRESSORS		SELTEC TM13								
PORTATA ARIA VENTILATORI EVAPORATORE EVAPORATING UNIT FAN AIR FLOW	m ³ /h	1080								
FRECCIA ARIA VENTILATORI EVAPORATORE EVAPORATING UNIT FAN AIR THROW	m	3,5								

DIMENSIONI / SIZES



IMBALLO / PACKING

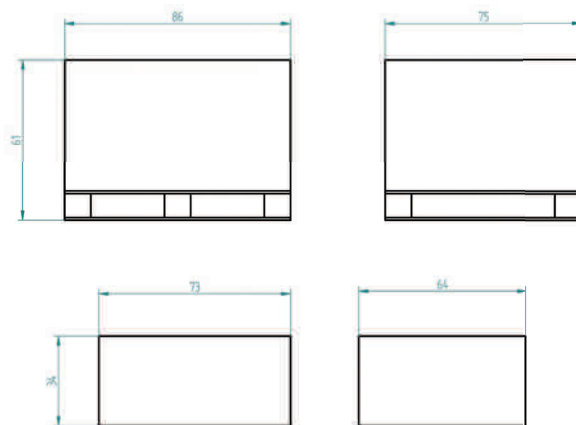

DOTAZIONE DI SERIE / STANDARD EQUIPMENT

- Unità condensatrice predisposta per montaggio a soffitto (in opzione montaggio a sbalzo) / Condensing Unit suitable for rooftop mounting (optional nose mounting)
- Unità evaporante predisposta per montaggio a soffitto (accessori per il fissaggio inclusi) / Evaporating Unit suitable for rooftop mounting (accessories included)
- Kit accessori scarico condensa / Water drain accessories
- Kit accessori (tubazioni e raccordi) per il collegamento frigorifero / Refrigeration connection kit (hoses and fittings)
- Kit accessori per il collegamento elettrico (cavi batteria) / Electrical connection kit (Vehicle battery power cables)
- Comando cabina / Cab Controller

NOTE / NOTES

- Il compressore "Strada" indicato è quello con cui è stata omologata l'unità, ma non è parte della dotazione standard
The "Road" compressor is the one used for the APT certification of the unit, but it's not in the standard equipment
- Il kit di staffaggio del compressore strada nel veicolo non è parte della dotazione standard
The "Road" compressor mounting kit is not in the standard equipment



FUNZIONAMENTO "STRADA"
"ROAD" OPERATION

















FUNZIONAMENTO "RETE"
"STAND-BY" OPERATION

Direct Drive Unit DDU020MCSZ11 ETR020Z11

RIVACOLD

TRUCK REFRIGERATION

SCHEDA DATI TECNICI / TECHNICAL DATASHEET

FUNZIONAMENTO OPERATING MODE		STRADA + RETE ROAD + STANDBY	
REFRIGERANTE REFRIGERANT		R404A	
Q.TÀ REFRIGERANTE REFRIGERANT CHARGE	kg	1,2	
CAPACITÀ FRIGORIFERA (TEMP. AMBIENTE +30°C) COOLING CAPACITY (AMBIENT TEMP. +30°C)	W	 1677  766 	 1068  411 
MAX VOLUME CELLA CONSIGLIATO (TEMP. AMBIENTE +30°C) MAX SUGGESTED ROOM VOLUME (AMBIENT TEMP. +30°C)	m³	11  7 	
ALIMENTAZIONE ELETTRICA POWER SUPPLY		 12 Vdc	 230 V / 1 ph / 50 Hz
ASSORBIMENTO MASSIMO MAXIMUM ABSORPTION		 21,2 A	 4,9 A / 1,25 kW
MOTORE ELETTRICO ELECTRIC MOTOR		-	
SBRINAMENTO DEFROST		GAS CALDO HOT GAS	
PESO UNITÀ CONDENSANTE CONDENSING UNIT WEIGHT	kg	60	
PESO UNITÀ EVAPORANTE EVAPORATING UNIT WEIGHT	kg	11	
COMPRESSORI COMPRESSORS		 SELTEC TM13	 TECUMSEH HGA2446Z
PORTATA ARIA VENTILATORI EVAPORATORE EVAPORATING UNIT FAN AIR FLOW	m³/h	1080	
FRECCIA ARIA VENTILATORI EVAPORATORE EVAPORATING UNIT FAN AIR THROW	m	3,5	

DIMENSIONI / SIZES

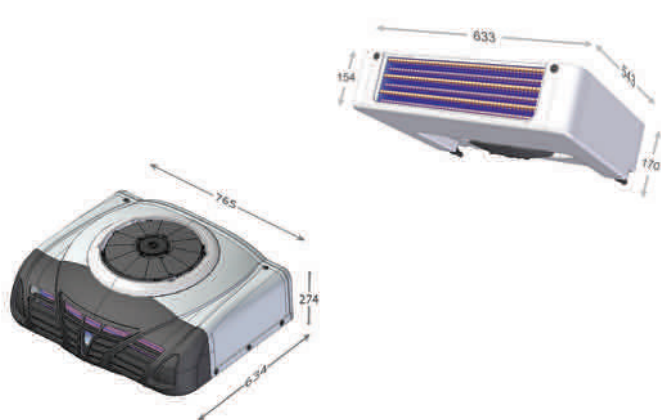

IMBALLO / PACKING

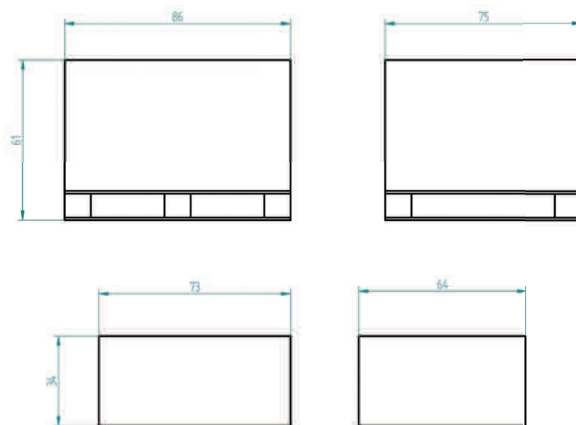

DOTAZIONE DI SERIE / STANDARD EQUIPMENT

- Unità condensatrice predisposta per montaggio a soffitto (in opzione montaggio a sbalzo) / Condensing Unit suitable for rooftop mounting (optional nose mounting)
- Unità evaporante predisposta per montaggio a soffitto (accessori per il fissaggio inclusi) / Evaporating Unit suitable for rooftop mounting (accessories included)
- Kit accessori scarico condensa / Water drain accessories
- Kit accessori (tubazioni e raccordi) per il collegamento frigorifero / Refrigeration connection kit (hoses and fittings)
- Kit accessori per il collegamento elettrico (cavi batteria, cavi e spine alimentazione rete) / Electrical connection kit (Vehicle battery power cables, Stand-by power cables and plugs)
- Comando cabina / Cab Controller

NOTE / NOTES

- Il compressore "Strada" indicato è quello con cui è stata omologata l'unità, ma non è parte della dotazione standard
The "Road" compressor is the one used for the APT certification of the unit, but it's not in the standard equipment
- Il kit di staffaggio del compressore strada nel veicolo non è parte della dotazione standard
The "Road" compressor mounting kit is not in the standard equipment



FUNZIONAMENTO "STRADA"
"ROAD" OPERATION



FUNZIONAMENTO "RETE"
"STAND-BY" OPERATION

Direct Drive Unit DDU025MCRZ10 ETR025Z11

RIVACOLD

TRUCK REFRIGERATION

SCHEDA DATI TECNICI / TECHNICAL DATASHEET

FUNZIONAMENTO OPERATING MODE		STRADA ROAD								
REFRIGERANTE REFRIGERANT		R404A								
Q.TÀ REFRIGERANTE REFRIGERANT CHARGE	kg	1,8								
CAPACITÀ FRIGORIFERA (TEMP. AMBIENTE +30°C) COOLING CAPACITY (AMBIENT TEMP. +30°C)	W	<table border="0"> <tr> <td rowspan="2">A</td> <td>2347</td> <td></td> <td rowspan="2">-</td> <td></td> </tr> <tr> <td>1213</td> <td></td> <td></td> </tr> </table>	A	2347		-		1213		
A	2347			-						
	1213									
MAX VOLUME CELLA CONSIGLIATO (TEMP. AMBIENTE +30°C) MAX SUGGESTED ROOM VOLUME (AMBIENT TEMP. +30°C)	m³	<table border="0"> <tr> <td></td> <td>17</td> <td></td> </tr> <tr> <td></td> <td>12</td> <td></td> </tr> </table>		17			12			
	17									
	12									
ALIMENTAZIONE ELETTRICA POWER SUPPLY		A 12 Vdc -								
ASSORBIMENTO MASSIMO MAXIMUM ABSORPTION		A 28,4 A -								
MOTORE ELETTRICO ELECTRIC MOTOR		-								
SBRINAMENTO DEFROST		GAS CALDO HOT GAS								
PESO UNITÀ CONDENSANTE CONDENSING UNIT WEIGHT	kg	45								
PESO UNITÀ EVAPORANTE EVAPORATING UNIT WEIGHT	kg	11								
COMPRESSORI COMPRESSORS		A SELTEC TM13 -								
PORTATA ARIA VENTILATORI EVAPORATORE EVAPORATING UNIT FAN AIR FLOW	m³/h	1080								
FRECCIA ARIA VENTILATORI EVAPORATORE EVAPORATING UNIT FAN AIR THROW	m	3,5								

DIMENSIONI / SIZES

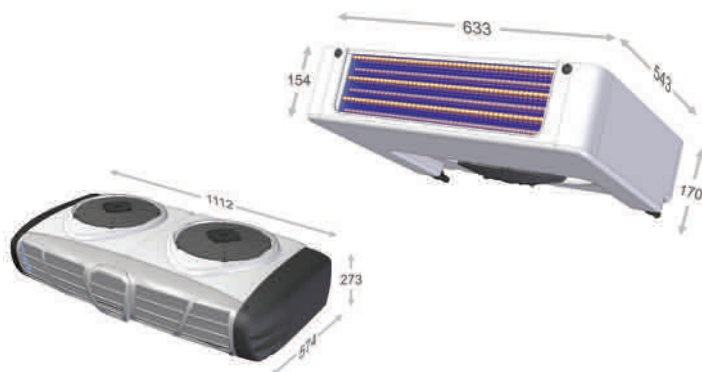

IMBALLO / PACKING

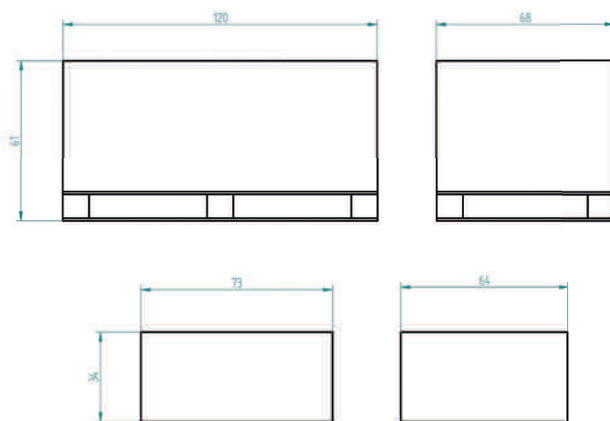

DOTAZIONE DI SERIE / STANDARD EQUIPMENT

- Unità condensatrice predisposta per montaggio a soffitto (in opzione montaggio a sbalzo) / Condensing Unit suitable for rooftop mounting (optional nose mounting)
- Unità evaporante predisposta per montaggio a soffitto (accessori per il fissaggio inclusi) / Evaporating Unit suitable for rooftop mounting (accessories included)
- Kit accessori scarico condensa / Water drain accessories
- Kit accessori (tubazioni e raccordi) per il collegamento frigorifero / Refrigeration connection kit (hoses and fittings)
- Kit accessori per il collegamento elettrico (cavi batteria) / Electrical connection kit (Vehicle battery power cables)
- Comando cabina / Cab Controller

NOTE / NOTES

- Il compressore "Strada" indicato è quello con cui è stata omologata l'unità, ma non è parte della dotazione standard
The "Road" compressor is the one used for the APT certification of the unit, but it's not in the standard equipment
- Il kit di staffaggio del compressore strada nel veicolo non è parte della dotazione standard
The "Road" compressor mounting kit is not in the standard equipment



FUNZIONAMENTO "STRADA"
"ROAD" OPERATION



















FUNZIONAMENTO "RETE"
"STAND-BY" OPERATION

Direct Drive Unit DDU025MCSZ11 ETR025Z11

RIVACOLD

TRUCK REFRIGERATION

SCHEDA DATI TECNICI / TECHNICAL DATASHEET

FUNZIONAMENTO OPERATING MODE		STRADA + RETE ROAD + STANDBY	
REFRIGERANTE REFRIGERANT		R404A	
Q.TÀ REFRIGERANTE REFRIGERANT CHARGE	kg	1,8	
CAPACITÀ FRIGORIFERA (TEMP. AMBIENTE +30°C) COOLING CAPACITY (AMBIENT TEMP. +30°C)	W	 2347   1213 	 1379   621 
MAX VOLUME CELLA CONSIGLIATO (TEMP. AMBIENTE +30°C) MAX SUGGESTED ROOM VOLUME (AMBIENT TEMP. +30°C)	m³	17  12 	
ALIMENTAZIONE ELETTRICA POWER SUPPLY		 12 Vdc	 230 V / 1 ph / 50 Hz
ASSORBIMENTO MASSIMO MAXIMUM ABSORPTION		 28,4 A	 13,5 A / 2,2 kW
MOTORE ELETTRICO ELECTRIC MOTOR		2	
SBRINAMENTO DEFROST		GAS CALDO HOT GAS	
PESO UNITÀ CONDENSANTE CONDENSING UNIT WEIGHT	kg	80	
PESO UNITÀ EVAPORANTE EVAPORATING UNIT WEIGHT	kg	11	
COMPRESSORI COMPRESSORS		 SELTEC TM13	 SANDEN SD5L09
PORTATA ARIA VENTILATORI EVAPORATORE EVAPORATING UNIT FAN AIR FLOW	m³/h	1080	
FRECCIA ARIA VENTILATORI EVAPORATORE EVAPORATING UNIT FAN AIR THROW	m	3,5	

DIMENSIONI / SIZES

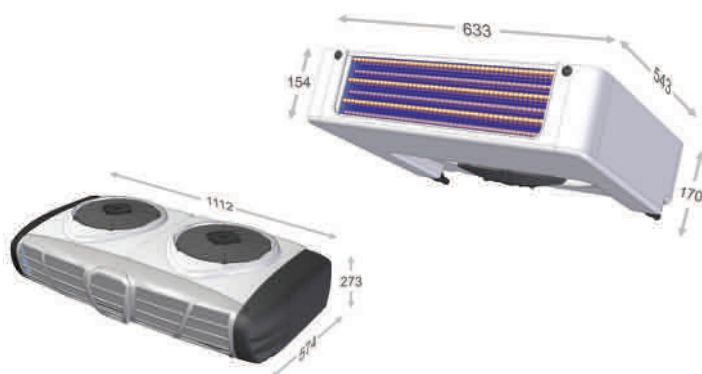

IMBALLO / PACKING

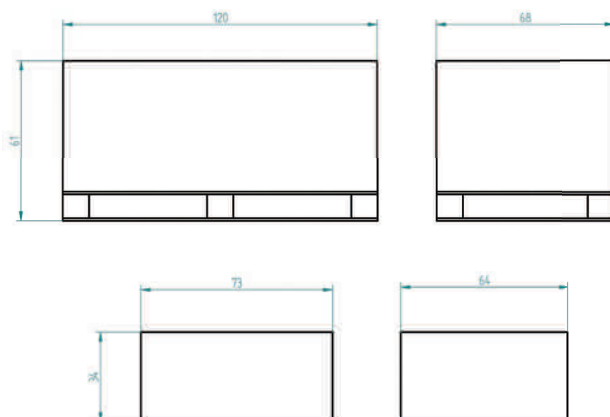

DOTAZIONE DI SERIE / STANDARD EQUIPMENT

- Unità condensatrice predisposta per montaggio a soffitto (in opzione montaggio a sbalzo) / Condensing Unit suitable for rooftop mounting (optional nose mounting)
- Unità evaporante predisposta per montaggio a soffitto (accessori per il fissaggio inclusi) / Evaporating Unit suitable for rooftop mounting (accessories included)
- Kit accessori scarico condensa / Water drain accessories
- Kit accessori (tubazioni e raccordi) per il collegamento frigorifero / Refrigeration connection kit (hoses and fittings)
- Kit accessori per il collegamento elettrico (cavi batteria, cavi e spine alimentazione rete) / Electrical connection kit (Vehicle battery power cables, Stand-by power cables and plugs)
- Comando cabina / Cab Controller

NOTE / NOTES

- Il compressore "Strada" indicato è quello con cui è stata omologata l'unità, ma non è parte della dotazione standard
The "Road" compressor is the one used for the APT certification of the unit, but it's not in the standard equipment
- Il kit di staffaggio del compressore strada nel veicolo non è parte della dotazione standard
The "Road" compressor mounting kit is not in the standard equipment



FUNZIONAMENTO "STRADA"
"ROAD" OPERATION



















FUNZIONAMENTO "RETE"
"STAND-BY" OPERATION

Direct Drive Unit DDU025MCSZ12 ETR025Z11

RIVACOLD

TRUCK REFRIGERATION

SCHEDA DATI TECNICI / TECHNICAL DATASHEET

FUNZIONAMENTO OPERATING MODE		STRADA + RETE ROAD + STANDBY	
REFRIGERANTE REFRIGERANT		R404A	
Q.TÀ REFRIGERANTE REFRIGERANT CHARGE	kg	1,8	
CAPACITÀ FRIGORIFERA (TEMP. AMBIENTE +30°C) COOLING CAPACITY (AMBIENT TEMP. +30°C)	W	2347  	1379  
		1213  	621  
MAX VOLUME CELLA CONSIGLIATO (TEMP. AMBIENTE +30°C) MAX SUGGESTED ROOM VOLUME (AMBIENT TEMP. +30°C)	m³	17  12 	
ALIMENTAZIONE ELETTRICA POWER SUPPLY		 12 Vdc	 400 V / 3 ph / 50 Hz
ASSORBIMENTO MASSIMO MAXIMUM ABSORPTION		 28,4 A	 5,9 A / 2,9 kW
MOTORE ELETTRICO ELECTRIC MOTOR		2	
SBRINAMENTO DEFROST		GAS CALDO HOT GAS	
PESO UNITÀ CONDENSANTE CONDENSING UNIT WEIGHT	kg	80	
PESO UNITÀ EVAPORANTE EVAPORATING UNIT WEIGHT	kg	11	
COMPRESSORI COMPRESSORS		 SELTEC TM13	 SANDEN SD5L09
PORTATA ARIA VENTILATORI EVAPORATORE EVAPORATING UNIT FAN AIR FLOW	m³/h	1080	
FRECCIA ARIA VENTILATORI EVAPORATORE EVAPORATING UNIT FAN AIR THROW	m	3,5	

DIMENSIONI / SIZES

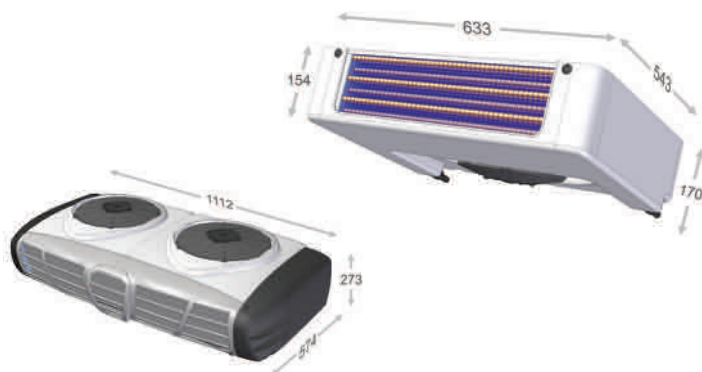

IMBALLO / PACKING

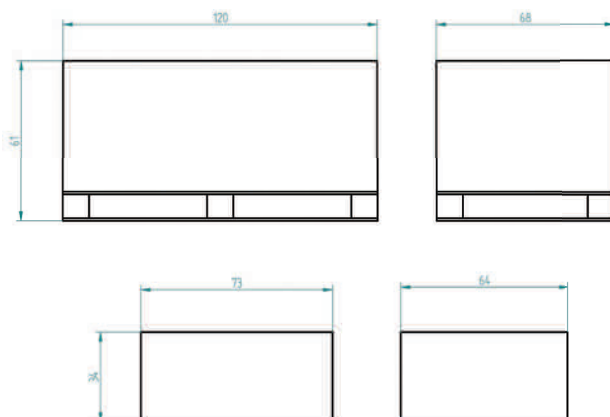

DOTAZIONE DI SERIE / STANDARD EQUIPMENT

- Unità condensatrice predisposta per montaggio a soffitto (in opzione montaggio a sbalzo) / Condensing Unit suitable for rooftop mounting (optional nose mounting)
- Unità evaporante predisposta per montaggio a soffitto (accessori per il fissaggio inclusi) / Evaporating Unit suitable for rooftop mounting (accessories included)
- Kit accessori scarico condensa / Water drain accessories
- Kit accessori (tubazioni e raccordi) per il collegamento frigorifero / Refrigeration connection kit (hoses and fittings)
- Kit accessori per il collegamento elettrico (cavi batteria, cavi e spine alimentazione rete) / Electrical connection kit (Vehicle battery power cables, Stand-by power cables and plugs)
- Comando cabina / Cab Controller

NOTE / NOTES

- Il compressore "Strada" indicato è quello con cui è stata omologata l'unità, ma non è parte della dotazione standard
The "Road" compressor is the one used for the APT certification of the unit, but it's not in the standard equipment
- Il kit di staffaggio del compressore strada nel veicolo non è parte della dotazione standard
The "Road" compressor mounting kit is not in the standard equipment



FUNZIONAMENTO "STRADA"
"ROAD" OPERATION



FUNZIONAMENTO "RETE"
"STAND-BY" OPERATION

Direct Drive Unit DDU035MCRZ10 ETR035Z21

RIVACOLD

TRUCK REFRIGERATION

SCHEDA DATI TECNICI / TECHNICAL DATASHEET

FUNZIONAMENTO OPERATING MODE		STRADA ROAD								
REFRIGERANTE REFRIGERANT		R404A								
Q.TÀ REFRIGERANTE REFRIGERANT CHARGE	kg	2,3								
CAPACITÀ FRIGORIFERA (TEMP. AMBIENTE +30°C) COOLING CAPACITY (AMBIENT TEMP. +30°C)	W	<table border="1"> <tr> <td>3422</td> <td></td> <td>-</td> <td></td> </tr> <tr> <td>1798</td> <td></td> <td>-</td> <td></td> </tr> </table>	3422		-		1798		-	
3422		-								
1798		-								
MAX VOLUME CELLA CONSIGLIATO (TEMP. AMBIENTE +30°C) MAX SUGGESTED ROOM VOLUME (AMBIENT TEMP. +30°C)	m ³	<table border="1"> <tr> <td>24</td> <td></td> </tr> <tr> <td>18</td> <td></td> </tr> </table>	24		18					
24										
18										
ALIMENTAZIONE ELETTRICA POWER SUPPLY		12 Vdc								
ASSORBIMENTO MASSIMO MAXIMUM ABSORPTION		37,5 A								
MOTORE ELETTRICO ELECTRIC MOTOR		-								
SBRINAMENTO DEFROST		GAS CALDO HOT GAS								
PESO UNITÀ CONDENSANTE CONDENSING UNIT WEIGHT	kg	45								
PESO UNITÀ EVAPORANTE EVAPORATING UNIT WEIGHT	kg	16								
COMPRESSORI COMPRESSORS		SELTEC TM13								
PORTATA ARIA VENTILATORI EVAPORATORE EVAPORATING UNIT FAN AIR FLOW	m ³ /h	2160								
FRECCIA ARIA VENTILATORI EVAPORATORE EVAPORATING UNIT FAN AIR THROW	m	4,5								

DIMENSIONI / SIZES

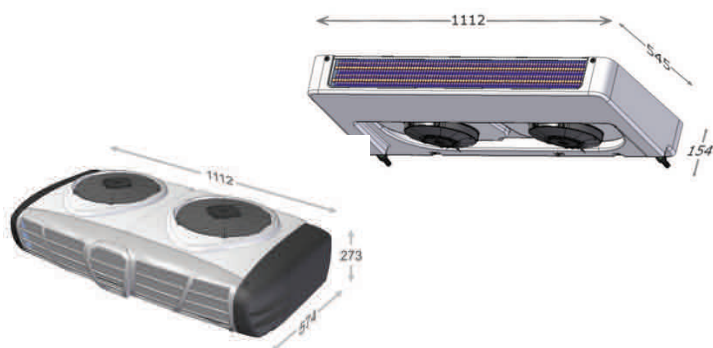

IMBALLO / PACKING

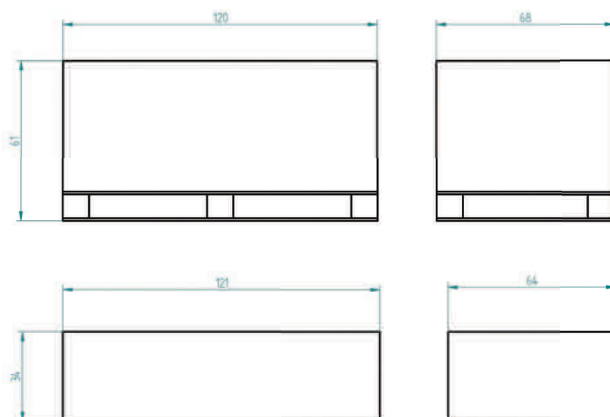

DOTAZIONE DI SERIE / STANDARD EQUIPMENT

- Unità condensatrice predisposta per montaggio a soffitto (in opzione montaggio a sbalzo) / Condensing Unit suitable for rooftop mounting (optional nose mounting)
- Unità evaporante predisposta per montaggio a soffitto (accessori per il fissaggio inclusi) / Evaporating Unit suitable for rooftop mounting (accessories included)
- Kit accessori scarico condensa / Water drain accessories
- Kit accessori (tubazioni e raccordi) per il collegamento frigorifero / Refrigeration connection kit (hoses and fittings)
- Kit accessori per il collegamento elettrico (cavi batteria) / Electrical connection kit (Vehicle battery power cables)
- Comando cabina / Cab Controller

NOTE / NOTES

- Il compressore "Strada" indicato è quello con cui è stata omologata l'unità, ma non è parte della dotazione standard
The "Road" compressor is the one used for the APT certification of the unit, but it's not in the standard equipment
- Il kit di staffaggio del compressore strada nel veicolo non è parte della dotazione standard
The "Road" compressor mounting kit is not in the standard equipment



FUNZIONAMENTO "STRADA"
"ROAD" OPERATION



















FUNZIONAMENTO "RETE"
"STAND-BY" OPERATION

Direct Drive Unit DDU035MCSZ11 ETR035Z21

RIVACOLD

TRUCK REFRIGERATION

SCHEDA DATI TECNICI / TECHNICAL DATASHEET

FUNZIONAMENTO OPERATING MODE		STRADA + RETE ROAD + STANDBY	
REFRIGERANTE REFRIGERANT		R404A	
Q.TÀ REFRIGERANTE REFRIGERANT CHARGE	kg	2,3	
CAPACITÀ FRIGORIFERA (TEMP. AMBIENTE +30°C) COOLING CAPACITY (AMBIENT TEMP. +30°C)	W	 3422 	 2408 
		 1798 	 1197 
MAX VOLUME CELLA CONSIGLIATO (TEMP. AMBIENTE +30°C) MAX SUGGESTED ROOM VOLUME (AMBIENT TEMP. +30°C)	m ³	24 	
		18 	
ALIMENTAZIONE ELETTRICA POWER SUPPLY		 12 Vdc	 230 V / 1 ph / 50 Hz
ASSORBIMENTO MASSIMO MAXIMUM ABSORPTION		 37,5 A	 13,5 A / 2,2 kW
MOTORE ELETTRICO ELECTRIC MOTOR		2	
SBRINAMENTO DEFROST		GAS CALDO HOT GAS	
PESO UNITÀ CONDENSANTE CONDENSING UNIT WEIGHT	kg	80	
PESO UNITÀ EVAPORANTE EVAPORATING UNIT WEIGHT	kg	16	
COMPRESSORI COMPRESSORS		 SELTEC TM15	 SANDEN SD5L09
PORTATA ARIA VENTILATORI EVAPORATORE EVAPORATING UNIT FAN AIR FLOW	m ³ /h	2160	
FRECCIA ARIA VENTILATORI EVAPORATORE EVAPORATING UNIT FAN AIR THROW	m	4,5	

DIMENSIONI / SIZES

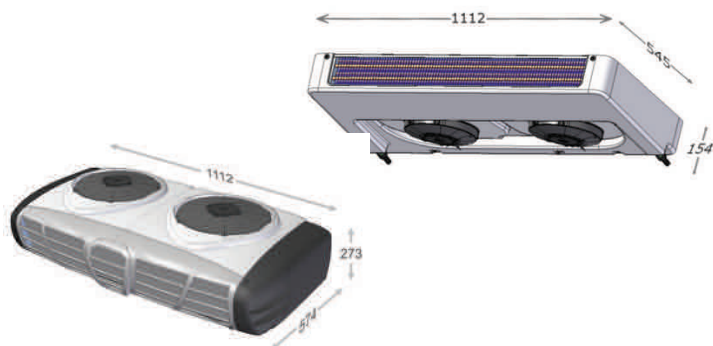

IMBALLO / PACKING

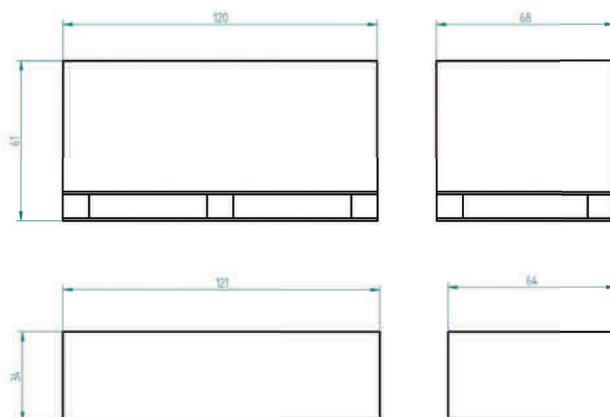

DOTAZIONE DI SERIE / STANDARD EQUIPMENT

- Unità condensatrice predisposta per montaggio a soffitto (in opzione montaggio a sbalzo) / Condensing Unit suitable for rooftop mounting (optional nose mounting)
- Unità evaporante predisposta per montaggio a soffitto (accessori per il fissaggio inclusi) / Evaporating Unit suitable for rooftop mounting (accessories included)
- Kit accessori scarico condensa / Water drain accessories
- Kit accessori (tubazioni e raccordi) per il collegamento frigorifero / Refrigeration connection kit (hoses and fittings)
- Kit accessori per il collegamento elettrico (cavi batteria, cavi e spine alimentazione rete) / Electrical connection kit (Vehicle battery power cables, Stand-by power cables and plugs)
- Comando cabina / Cab Controller

NOTE / NOTES

- Il compressore "Strada" indicato è quello con cui è stata omologata l'unità, ma non è parte della dotazione standard
The "Road" compressor is the one used for the APT certification of the unit, but it's not in the standard equipment
- Il kit di staffaggio del compressore strada nel veicolo non è parte della dotazione standard
The "Road" compressor mounting kit is not in the standard equipment



FUNZIONAMENTO "STRADA"
"ROAD" OPERATION



















FUNZIONAMENTO "RETE"
"STAND-BY" OPERATION

Direct Drive Unit DDU035MCSZ12 ETR035Z21

RIVACOLD

TRUCK REFRIGERATION

SCHEDA DATI TECNICI / TECHNICAL DATASHEET

FUNZIONAMENTO OPERATING MODE		STRADA + RETE ROAD + STANDBY	
REFRIGERANTE REFRIGERANT		R404A	
Q.TÀ REFRIGERANTE REFRIGERANT CHARGE	kg	2,3	
CAPACITÀ FRIGORIFERA (TEMP. AMBIENTE +30°C) COOLING CAPACITY (AMBIENT TEMP. +30°C)	W	3422  	2408  
		1798  	1197  
MAX VOLUME CELLA CONSIGLIATO (TEMP. AMBIENTE +30°C) MAX SUGGESTED ROOM VOLUME (AMBIENT TEMP. +30°C)	m ³	24  18 	
ALIMENTAZIONE ELETTRICA POWER SUPPLY		 12 Vdc	 400 V / 3 ph / 50 Hz
ASSORBIMENTO MASSIMO MAXIMUM ABSORPTION		 37,5 A	 5,9 A / 2,9 kW
MOTORE ELETTRICO ELECTRIC MOTOR		2	
SBRINAMENTO DEFROST		GAS CALDO HOT GAS	
PESO UNITÀ CONDENSANTE CONDENSING UNIT WEIGHT	kg	80	
PESO UNITÀ EVAPORANTE EVAPORATING UNIT WEIGHT	kg	16	
COMPRESSORI COMPRESSORS		 SELTEC TM13	 SANDEN SD5L09
PORTATA ARIA VENTILATORI EVAPORATORE EVAPORATING UNIT FAN AIR FLOW	m ³ /h	2160	
FRECCIA ARIA VENTILATORI EVAPORATORE EVAPORATING UNIT FAN AIR THROW	m	4,5	

DIMENSIONI / SIZES

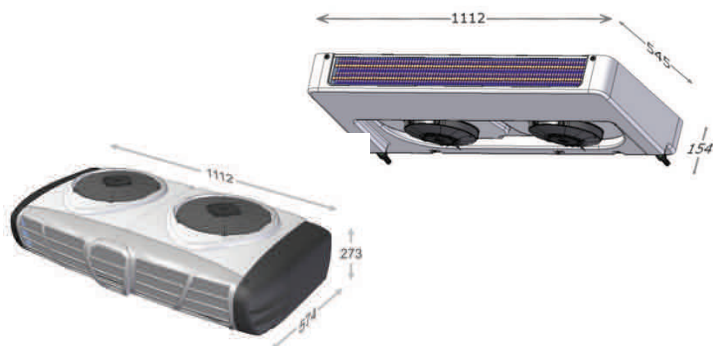

IMBALLO / PACKING

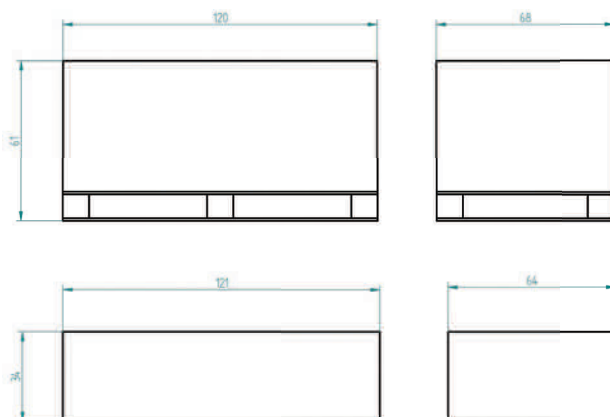

DOTAZIONE DI SERIE / STANDARD EQUIPMENT

- Unità condensatrice predisposta per montaggio a soffitto (in opzione montaggio a sbalzo) / Condensing Unit suitable for rooftop mounting (optional nose mounting)
- Unità evaporante predisposta per montaggio a soffitto (accessori per il fissaggio inclusi) / Evaporating Unit suitable for rooftop mounting (accessories included)
- Kit accessori scarico condensa / Water drain accessories
- Kit accessori (tubazioni e raccordi) per il collegamento frigorifero / Refrigeration connection kit (hoses and fittings)
- Kit accessori per il collegamento elettrico (cavi batteria, cavi e spine alimentazione rete) / Electrical connection kit (Vehicle battery power cables, Stand-by power cables and plugs)
- Comando cabina / Cab Controller

NOTE / NOTES

- Il compressore "Strada" indicato è quello con cui è stata omologata l'unità, ma non è parte della dotazione standard
The "Road" compressor is the one used for the APT certification of the unit, but it's not in the standard equipment
- Il kit di staffaggio del compressore strada nel veicolo non è parte della dotazione standard
The "Road" compressor mounting kit is not in the standard equipment



FUNZIONAMENTO "STRADA"
"ROAD" OPERATION

















FUNZIONAMENTO "RETE"
"STAND-BY" OPERATION

Direct Drive Unit DDU040MCRZ10 ETR040Z21

RIVACOLD

TRUCK REFRIGERATION

SCHEDA DATI TECNICI / TECHNICAL DATASHEET

FUNZIONAMENTO OPERATING MODE		STRADA ROAD	
REFRIGERANTE REFRIGERANT		R404A	
Q.TÀ REFRIGERANTE REFRIGERANT CHARGE	kg	2,45	
CAPACITÀ FRIGORIFERA (TEMP. AMBIENTE +30°C) COOLING CAPACITY (AMBIENT TEMP. +30°C)	W	 3766 	 - 
		1890 	- 
MAX VOLUME CELLA CONSIGLIATO (TEMP. AMBIENTE +30°C) MAX SUGGESTED ROOM VOLUME (AMBIENT TEMP. +30°C)	m ³	27 	
		20 	
ALIMENTAZIONE ELETTRICA POWER SUPPLY		 12 Vdc	 -
ASSORBIMENTO MASSIMO MAXIMUM ABSORPTION		 37,5 A	 -
MOTORE ELETTRICO ELECTRIC MOTOR		-	
SBRINAMENTO DEFROST		GAS CALDO HOT GAS	
PESO UNITÀ CONDENSANTE CONDENSING UNIT WEIGHT	kg	45	
PESO UNITÀ EVAPORANTE EVAPORATING UNIT WEIGHT	kg	17,5	
COMPRESSORI COMPRESSORS		 SELTEC TM15	 -
PORTATA ARIA VENTILATORI EVAPORATORE EVAPORATING UNIT FAN AIR FLOW	m ³ /h	2160	
FRECCIA ARIA VENTILATORI EVAPORATORE EVAPORATING UNIT FAN AIR THROW	m	4,5	

DIMENSIONI / SIZES

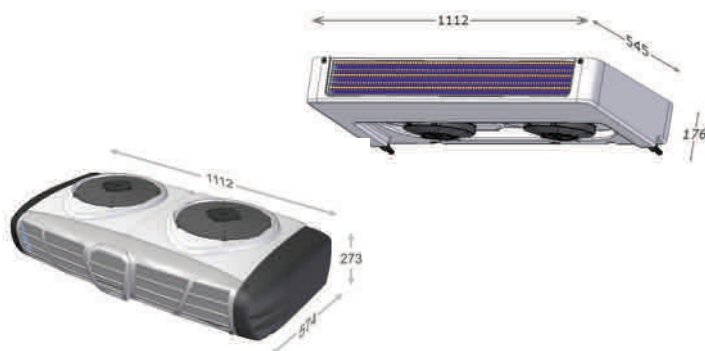

IMBALLO / PACKING

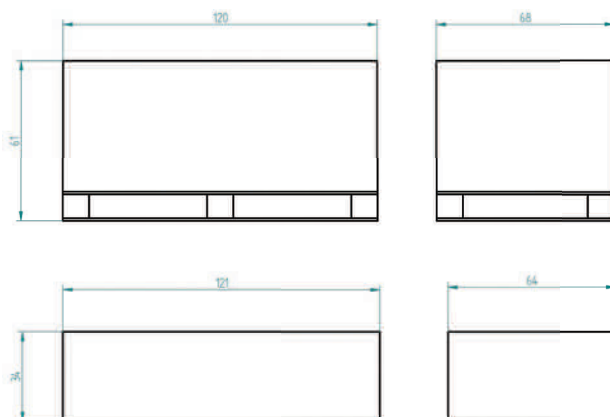

DOTAZIONE DI SERIE / STANDARD EQUIPMENT

- Unità condensatrice predisposta per montaggio a soffitto (in opzione montaggio a sbalzo) / Condensing Unit suitable for rooftop mounting (optional nose mounting)
- Unità evaporante predisposta per montaggio a soffitto (accessori per il fissaggio inclusi) / Evaporating Unit suitable for rooftop mounting (accessories included)
- Kit accessori scarico condensa / Water drain accessories
- Kit accessori (tubazioni e raccordi) per il collegamento frigorifero / Refrigeration connection kit (hoses and fittings)
- Kit accessori per il collegamento elettrico (cavi batteria) / Electrical connection kit (Vehicle battery power cables)
- Comando cabina / Cab Controller

NOTE / NOTES

- Il compressore "Strada" indicato è quello con cui è stata omologata l'unità, ma non è parte della dotazione standard
The "Road" compressor is the one used for the APT certification of the unit, but it's not in the standard equipment
- Il kit di staffaggio del compressore strada nel veicolo non è parte della dotazione standard
The "Road" compressor mounting kit is not in the standard equipment



FUNZIONAMENTO "STRADA"
"ROAD" OPERATION









FUNZIONAMENTO "RETE"
"STAND-BY" OPERATION

Direct Drive Unit DDU040MCSZ11 ETR040Z21

RIVACOLD

TRUCK REFRIGERATION

SCHEDA DATI TECNICI / TECHNICAL DATASHEET

FUNZIONAMENTO OPERATING MODE		STRADA + RETE ROAD + STANDBY	
REFRIGERANTE REFRIGERANT		R404A	
Q.TÀ REFRIGERANTE REFRIGERANT CHARGE	kg	2,45	
CAPACITÀ FRIGORIFERA (TEMP. AMBIENTE +30°C) COOLING CAPACITY (AMBIENT TEMP. +30°C)	W	3766  0°C	3021  0°C
		1890  -20°C	1275  -20°C
MAX VOLUME CELLA CONSIGLIATO (TEMP. AMBIENTE +30°C) MAX SUGGESTED ROOM VOLUME (AMBIENT TEMP. +30°C)	m³	27  0°C	20  -20°C
ALIMENTAZIONE ELETTRICA POWER SUPPLY		12 Vdc	230 V / 1 ph / 50 Hz
ASSORBIMENTO MASSIMO MAXIMUM ABSORPTION		37,5 A	13,5 A / 2,2 kW
MOTORE ELETTRICO ELECTRIC MOTOR		2	
SBRINAMENTO DEFROST		GAS CALDO HOT GAS	
PESO UNITÀ CONDENSANTE CONDENSING UNIT WEIGHT	kg	80	
PESO UNITÀ EVAPORANTE EVAPORATING UNIT WEIGHT	kg	17,5	
COMPRESSORI COMPRESSORS		SELTEC TM13	SANDEN SD5L09
PORTATA ARIA VENTILATORI EVAPORATORE EVAPORATING UNIT FAN AIR FLOW	m³/h	2160	
FRECCIA ARIA VENTILATORI EVAPORATORE EVAPORATING UNIT FAN AIR THROW	m	4,5	

DIMENSIONI / SIZES

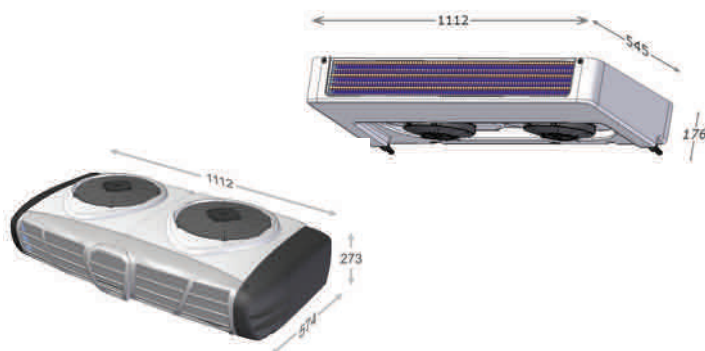

IMBALLO / PACKING

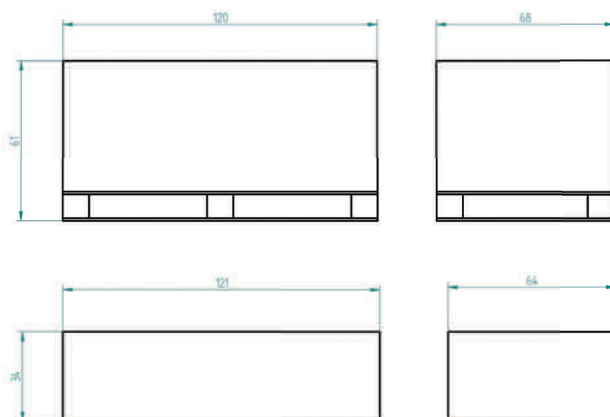

DOTAZIONE DI SERIE / STANDARD EQUIPMENT

- Unità condensatrice predisposta per montaggio a soffitto (in opzione montaggio a sbalzo) / Condensing Unit suitable for rooftop mounting (optional nose mounting)
- Unità evaporante predisposta per montaggio a soffitto (accessori per il fissaggio inclusi) / Evaporating Unit suitable for rooftop mounting (accessories included)
- Kit accessori scarico condensa / Water drain accessories
- Kit accessori (tubazioni e raccordi) per il collegamento frigorifero / Refrigeration connection kit (hoses and fittings)
- Kit accessori per il collegamento elettrico (cavi batteria, cavi e spine alimentazione rete) / Electrical connection kit (Vehicle battery power cables, Stand-by power cables and plugs)
- Comando cabina / Cab Controller

NOTE / NOTES

- Il compressore "Strada" indicato è quello con cui è stata omologata l'unità, ma non è parte della dotazione standard
The "Road" compressor is the one used for the APT certification of the unit, but it's not in the standard equipment
- Il kit di staffaggio del compressore strada nel veicolo non è parte della dotazione standard
The "Road" compressor mounting kit is not in the standard equipment



FUNZIONAMENTO "STRADA"
"ROAD" OPERATION











FUNZIONAMENTO "RETE"
"STAND-BY" OPERATION

Direct Drive Unit DDU040MCSZ12 ETR040Z21

RIVACOLD

TRUCK REFRIGERATION

SCHEDA DATI TECNICI / TECHNICAL DATASHEET

FUNZIONAMENTO OPERATING MODE		STRADA + RETE ROAD + STANDBY	
REFRIGERANTE REFRIGERANT		R404A	
Q.TÀ REFRIGERANTE REFRIGERANT CHARGE	kg	2,45	
CAPACITÀ FRIGORIFERA (TEMP. AMBIENTE +30°C) COOLING CAPACITY (AMBIENT TEMP. +30°C)	W	A 3766 	3021 
		1890 	1275 
MAX VOLUME CELLA CONSIGLIATO (TEMP. AMBIENTE +30°C) MAX SUGGESTED ROOM VOLUME (AMBIENT TEMP. +30°C)	m³	27 	
		20 	
ALIMENTAZIONE ELETTRICA POWER SUPPLY		A 12 Vdc	 400 V / 3 ph / 50 Hz
ASSORBIMENTO MASSIMO MAXIMUM ABSORPTION		A 37,5 A	 5,9 A / 2,9 kW
MOTORE ELETTRICO ELECTRIC MOTOR		2	
SBRINAMENTO DEFROST		GAS CALDO HOT GAS	
PESO UNITÀ CONDENSANTE CONDENSING UNIT WEIGHT	kg	80	
PESO UNITÀ EVAPORANTE EVAPORATING UNIT WEIGHT	kg	17,5	
COMPRESSORI COMPRESSORS		A SELTEC TM15	 SANDEN SD5L09
PORTATA ARIA VENTILATORI EVAPORATORE EVAPORATING UNIT FAN AIR FLOW	m³/h	2160	
FRECCIA ARIA VENTILATORI EVAPORATORE EVAPORATING UNIT FAN AIR THROW	m	4,5	

DIMENSIONI / SIZES

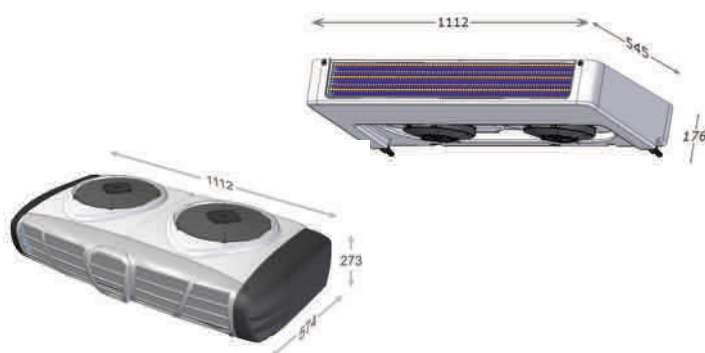

IMBALLO / PACKING

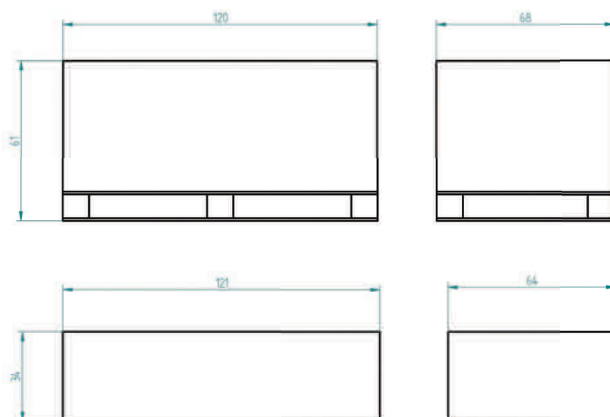

DOTAZIONE DI SERIE / STANDARD EQUIPMENT

- Unità condensatrice predisposta per montaggio a soffitto (in opzione montaggio a sbalzo) / Condensing Unit suitable for rooftop mounting (optional nose mounting)
- Unità evaporante predisposta per montaggio a soffitto (accessori per il fissaggio inclusi) / Evaporating Unit suitable for rooftop mounting (accessories included)
- Kit accessori scarico condensa / Water drain accessories
- Kit accessori (tubazioni e raccordi) per il collegamento frigorifero / Refrigeration connection kit (hoses and fittings)
- Kit accessori per il collegamento elettrico (cavi batteria, cavi e spine alimentazione rete) / Electrical connection kit (Vehicle battery power cables, Stand-by power cables and plugs)
- Comando cabina / Cab Controller

NOTE / NOTES

- Il compressore "Strada" indicato è quello con cui è stata omologata l'unità, ma non è parte della dotazione standard
The "Road" compressor is the one used for the APT certification of the unit, but it's not in the standard equipment
- Il kit di staffaggio del compressore strada nel veicolo non è parte della dotazione standard
The "Road" compressor mounting kit is not in the standard equipment



FUNZIONAMENTO "STRADA"
"ROAD" OPERATION



FUNZIONAMENTO "RETE"
"STAND-BY" OPERATION

RIVACOLD

TRUCK REFRIGERATION

A MEMBER OF



VITRI ALCESTE GROUP

Rivacold S.r.l.

Via Sicilia, 7 - Frazione Montecchio - 61022 Vallefoglia (PU) - Italy

Tel. +39 0721 919911 - Fax +39 0721 490015

www.rivacold.com - info@rivacold.com